

# TRANSDUCTION



## USER'S MANUAL

Version 1.0

05/21/09

TR-6001-PM NEMA 4 Panel Mount PC  
TR-6001-RM NEMA 4 Rack Mount PC  
with Intel Core 2 Quad and Core 2 Duo  
and Celeron D Processor

5155-23 Spectrum Way, Mississauga, ON, Canada L4W 5A1  
TEL: 1-800-268-0427, 905-625-1907  
FAX: 905-625-0531

# Table of Contents

Important Information .....	i
Warranty .....	ii
Recommended Use .....	ii
Chapter 1 - Introduction	
Contents .....	2
TR-6001 Specifications .....	3-4
Driver Installation .....	5
Touchscreen .....	6-15
Chapter 2 - TR-980 SBC Introduction	
Features .....	17
Specifications .....	18-20
Chapter 3 - Installations	
Jumpers on the TR-980 .....	22-25
Connectors on the TR-980 .....	26-41
Chapter 4 - BIOS Configuration	
Main Menu .....	43-45
Standard CMOS Setup .....	46-51
Advanced BIOS Features .....	52-58
Advanced Chipset Features .....	59-62
Integrated Peripherals .....	63-71
Power Management Setup .....	72-77
PnP/PCI Configuration .....	78-82
PC Health Status .....	83-84
Frequency/Voltage Control .....	85
Load Fail-Safe Defaults .....	85
Load Optimized Defaults .....	86-87
Supervisor/User Password Settings .....	88
Exit Selecting .....	88
Chapter 5 - Appendix	
I/O Port Address Map .....	90
Interrupt Request Lines (IRQ) .....	91
POST Beep .....	92
TR-6001 Mechanical Drawings .....	93-100

## **Important Information**

*The information in this document is subject to change without notice.*

*All relevant issues have been considered in the preparation of this document.*

*Should you notice an omission or any questionable item in this document, please feel free to notify Transduction. Regardless of the foregoing statement, Transduction assumes no responsibility for any errors that may appear in this document nor for results obtained by the user as a result of using this product.*

## **Copyright © 2009 Transduction. All rights reserved.**

*This document is protected by copyright. No part of this document may be reproduced, copied or translated in any form or means without prior written permission from Transduction. All other trademarks, brand and product names are the property of their respective owners.*

## **Return policy**

*Products returned for repair must be accompanied by a Return Material Authorization (RMA) number, obtained from Transduction prior to return.*

*Freight on all returned items must be prepaid by the customer. The customer is responsible for any loss or damage caused by the carrier in transit. To obtain an RMA number, call us at 905-625-1907. We will need the following information:*

- *Return company address and contract*
- *Model name, model number and serial number*
- *Description of the failure*

*Mark the RMA number clearly on the outside of each box, include a failure report*

*and return the product to:*

*Transduction*

*5155 – 23 Spectrum Way*

*Mississauga ON Canada L4W 5A1*

*Attn: RMA Department*

## Recommended Use

### Safety Precautions and Maintenance



FOR OPTIMUM PERFORMANCE, PLEASE NOTE  
THE FOLLOWING WHEN SETTING UP  
AND USING THE **TR-6001**:

- **DO NOT OPEN THE MONITOR.** There are no user serviceable parts inside and opening or removing covers may expose you to dangerous shock hazards or other risks. Refer all servicing to qualified service personnel.
- Do not spill any liquids into the cabinet or use your monitor near water.
- Do not insert objects of any kind into the cabinet slots, as they may touch dangerous voltage points, which can be harmful or fatal or may cause electric shock, fire or equipment failure.
- Do not place any heavy objects on the power cord. Damage to the cord may cause shock or fire.
- Do not place this product on a sloping or unstable cart, stand or table, as the monitor may fall, causing serious damage to the monitor.
- When operating the **TR-6001** with its AC 125-240V power supply, use a power supply cord that matches the power supply voltage of the AC power outlet being used. The power supply cord you use must have been approved by and comply with the safety standards of your country. (Type H05VV-F should be used in Europe)
- In UK, use a BS-approved power cord with molded plug having a black (5A) fuse installed for use with this monitor. If a power cord is not supplied with this monitor, please contact your supplier.
- Do not place any objects onto the monitor and do not use outdoors.
- The inside of the fluorescent tube located within the LCD monitor contains mercury. Please follow the bylaws or rules of your municipality to dispose of the tube properly.

Immediately unplug your unit from the power source and refer servicing to qualified service personnel under the following conditions:

- When the power supply cord or plug is damaged.
- If liquid has been spilled, or objects have fallen into the unit.
- If the unit has been exposed to rain or water.
- If the unit has been dropped or the cabinet damaged.
- If the unit does not operate normally by following operating instructions.
- Do not bend power cord.
- Do not use in high temperature, humid, dusty, or oily areas.
- If glass is broken, handle with care.
- Do not cover vents on unit.
- If monitor or glass is broken, do not come in contact with the liquid crystal and handle with care.
- Allow adequate ventilation around the unit so that heat can properly dissipate. Do not block ventilated openings or place near a radiator or other heat sources.
- Handle with care when transporting. Save packaging for transporting.

# 1

---

## Introduction

This chapter is designed to give you an overview on the TR-6001 industrial PC. The topics covered are as follows:

Contents .....	2
TR-6001 Specifications .....	3-4
Driver Installation .....	5
Touchscreen .....	6-15

# Contents

Your new **TR-6001** box\* should contain the following:

- **TR-6001** PC/LCD
- Power Cord
- User's Manual
- CD-ROM with drivers

Power Cord



TR-6001 Panel/Rack Mount PC

TRANSDUCTION



USER'S MANUAL  
TR-6001 NEMA 4X Panel Mount PC  
with LCD TFT Touch Screen  
To learn about this product, please refer to the manual provided.

User's Manual



Driver CD

*\*Remember to save your original box and packing material to transport or ship the monitor.*

# TR-6001 Specifications

<b>Model</b>	TR-6001 NEMA 4 Panel Mount and Rack Mount Industrial PC with TFT LCD Touch Screen
<b>Processor</b>	Intel Socket 775 for Core 2 Quad, Core 2 Duo or Celeron D with 800/1066/1333MHz FSB
<b>Display</b>	15" TFT LCD display Resolution - 1024 x 768 (XGA) Backlight MTBF 50,000 hours Brightness - 250cd/m <sup>2</sup> Contrast Ratio - 350:1 USB resistive touch screen
<b>Memory</b>	2 x 240 pin DIMM sockets, up to 4GB DDR2 memory
<b>Drive Bay</b>	2 x 3.5" HDD (RAID 1 Ok) or Flash SSD 1 x 5.25" SLIM CD-ROM or 1 x 5.25" SLIM DVD-ROM/CD-RW
<b>Expansion Slots</b>	2 x ISA slots and 4 x PCI slots
<b>SVGA</b>	Intel Q35 integrated GMA3100 graphic engine Supports DVMT 4.0 for memory allocation up to 256MB
<b>Ethernet</b>	2 x Realtek RT8111C on board for Dual Gigabits LAN
<b>Solid State Disk</b>	High speed flash SATA SSD 32GB ~ 256GB
<b>I/O</b>	2 x Serial RS-232 2 x USB 2.0 2 x RJ-45 LAN 1 x LPT PS/2/keyboard/mouse connectors
<b>Watchdog Timer</b>	1 ~ 255 seconds
<b>Cooling</b>	1 x CPU cooling fan connector near CPU socket 1 x system cooling fan connectors for chassis or power supply cooling
<b>Power</b>	Output rating - 300W Input Voltage - 100 ~ 240VAC @ 47/63Hz Optional DC input power - 12V, 24V, 48V, 125V and 250V MTBF 80,000 hours Safety - UL, cUL, TUV, FCC and CE approved
<b>System Monitor</b>	Monitor processor temperature, system temperature and DC power voltages
<b>Operating Temperature</b>	Operating Temperature: 0° ~ 60°C (32° ~ 140°F) Relative Humidity: 5 ~ 95%

<b>Dimensions</b>	17.25" (W) x 14.25" (H) x 6.4" (D) (6.25" (D) behind front panel) Rack mount version is 8U high N.W. 25 lbs, G.W. 30 lbs, CUFT. 6
<b>Chassis Colour</b>	Black, OEM colour optional
<b>Warranty</b>	3 years or 10% initial cost for 5 years
<b>Additional Options</b>	9U rack mount version Rear access Floppy/CD option Wall mounting bracket High speed flash SATA SSD 32 ~ 256GB IDE RAID 1 option BNC IRIG A/B time sync option

# Driver Installation

The Driver CD will auto-run when inserted in the CDROM drive. It will detect and select your single board computer and will help you to install the drivers automatically.

## **Install Related Chipset INF Driver**

The selection helps you to install the INF of related chipset interface.

## **Install VGA Driver**

The selection helps you to install the driver of the on-board VGA interface.

## **Install LAN Driver**

The selection helps you to install the driver of the on-board LAN interface.

## **Install Audio Driver**

The selection helps you to install the driver of the on-board audio interface.

## **Install Hi-Speed USB 2.0 Driver**

The selection helps you to install the driver of the on-board USB 2.0 interface.

## **Browse the CD**

The selection helps you to find the drivers in this CD directly.

# Touchscreen

## USB Controller Driver Installation

All Windows drivers are included on the Transduction **TR-6001** 8-wire Touchscreen Drivers CD along with Troubleshooting.

**NOTE:** For Win XP and 2000 you **MUST** logon with administrator's password.

**TouchKit** software on the driver CD has the required drivers and the utility for toggling between left and right mouse buttons and configuration support. These will all be installed when Setup.exe is run from the CD.

### For Windows 2000/XP

When the New Hardware Found message comes up, choose **Cancel**. Run the **Setup.exe** program from the driver CD.

Please note that the touch screen controller in the TR-6190 is **USB** and follow the prompts accordingly.

Windows will copy the files to your hard drive and setup will be complete. (Windows XP will give a warning message about the TouchKit Controller certification, press **Continue** anyway.)

Please reboot your computer.

Windows will now find the device automatically and it will be listed in the Device Manager as: *TouchKit USB Controller*.

### TouchKit Software

There are five property pages:

1. **GENERAL:** Language selection, add/remove devices, 4-point Calibration, Draw Test and Advanced

#### 4 pts Cal

Choose to calibrate your screen by touching the blinking symbol on the panel until you get a beep or it stops blinking



### Draw Test

Test the drawing position in relation to the display screen to verify panel linearity, calibration capability and drawing line quality.

### Advanced

A 25 Point calibration utility for the touch sensor.

Press **Clear** to clear previous calibration records.

Press **25 pts Cal** to do 25 point calibration by touching the blinking symbol on the panel until you get a beep or it stops blinking. After calibration, the new record will overwrite the old one.



## 2. SETTING: Sound, Mouse Mode and Double Click Adjustment

### Sound

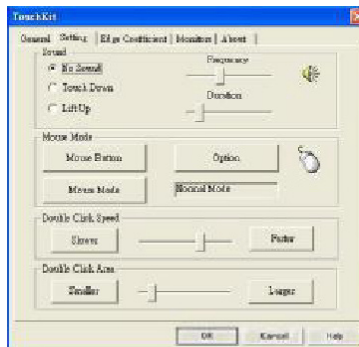

### No Sound

Choose to make no sound when panel is touched.

### Touch Down

Beep will sound when panel is touched.

### Lift Up

The system will not make any sound until finger leaves the touch panel.

### Frequency

Sound frequency, drag the cursor from left to right = low to high.

### Duration

Sound duration, drag the cursor from left to right = short to long.

### Mouse Mode

The **Mouse Mode** provides users different operating options.

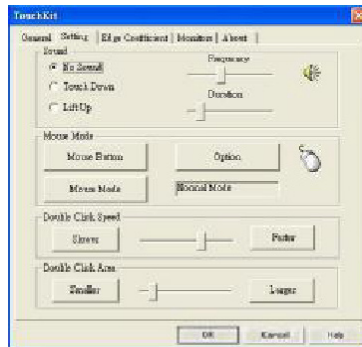

### Mouse Button

Click it to **show/hide Touch Tray** on the right bottom corner of the desktop.

Users can choose show or hide **Touch Tray** from the mouse icon in the taskbar.

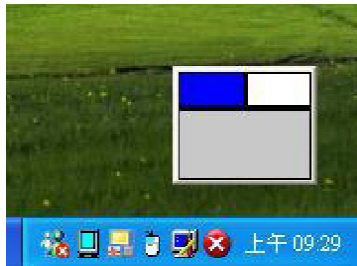

Change **right/left** button by clicking the upper small rectangular box of **Touch Tray**.

Blue area indicates which button has been selected.

### Shutdown utility



Click on shutdown utility in the task bar

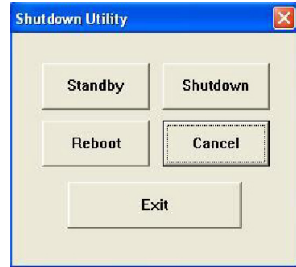

Shutdown utility dialog

There are five modes in shutdown utility:

**[Standby]** to enter standby mode that saves power consumption.

**[Shutdown]** to turn off PC.

**[Reboot]** to restart PC.

**[Cancel]** to escape from the Shutdown utility dialog.

**[Exit]** to disable the Shutdown utility.

**Please note that Windows NT does not support this function.**

### Mouse Mode

There are three mouse modes:

**[Normal Mode]**

Provides all the mouse functions, including the dragging function.

**[Click on Touch]**

Click action is executed as soon as panel is touched.

**[Click on Release]**

Click action will not be executed until finger leaves the panel.

### Option

**Touchkit** provides an option for advanced Mouse Emulation setting.

When the **Option** button is pressed, a setting property sheet will pop up.

**Support Constant Touch** and **Support Auto Right Button** check boxes

are shown in the property sheet to

**enable/disable constant touch** and **Auto right button** support.

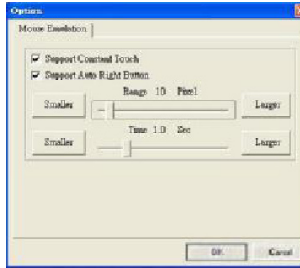

### Constant Touch

Enable **Constant Touch** to force driver to stop reporting touch points when movement is slight. You will see a stabilized cursor instead of a chattering cursor when users touch the same point. Eliminates unwanted noise.

### Auto Right Button

Enable **Auto Right Button** to force driver to report a **right click mouse event** to OS when users lift up from a **constant touch**. You no longer need to touch the **right button** in the touchtray to activate a right click. This makes it easier to right click.

### Cursor Visibility

Cursor visibility function allows the cursor to be hidden. Go to **Start / Control Panel / Mouse / Pointers / Scheme**, and choose **TouchKit Hide Cursor**. Press **[Apply]** to make the setting change, and press **[OK]** to escape the property page.

### Double Click Adjustment

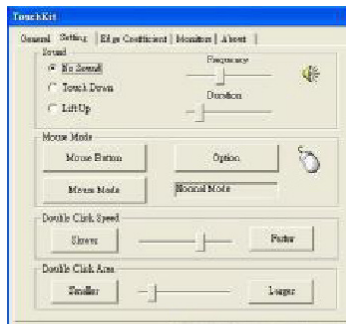

### Double Click Speed

Double Click Speed is the double click response time for the Windows system. Users can adjust the speed for easy double click by touch panel.

### Double Click Area

Each individual touch has its own touch tolerance. If the Double Click Area is set to **<Smaller>**, the panel will be very sensitive about micro-movements when you want to fix on a point. If set to **<Larger>**, larger touch point movement is tolerated when you want to point at a fixed position.

### 3. EDGE COEFFICIENT: Edge compensation for Top, Bottom, Left, Right, X Axis and Y Axis

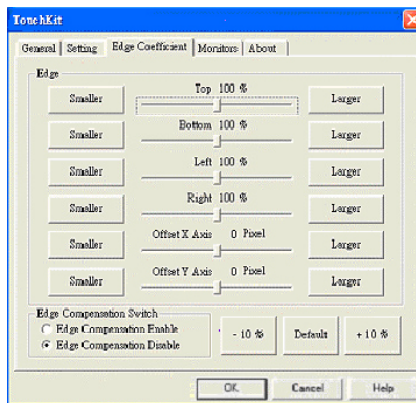

If it is difficult to touch items at the edges of the touch panel, you can adjust the edges of the screen image.

#### Top

If you set the Edge to **<Smaller>**, TouchKit will reduce the horizontal position of the top edge. If you set the Edge to **<Larger>**, TouchKit will extend the horizontal position of the top edge.

## Bottom

If you set the Edge to **<Smaller>**, TouchKit will reduce the horizontal position of the bottom edge. If you set the Edge to **<Larger>**, TouchKit will extend the horizontal position of the bottom edge.

## Left

If you set the Edge to **<Smaller>**, TouchKit will reduce the vertical position of the left edge. If you set the Edge to **<Larger>**, TouchKit will extend the vertical position of the left edge.

## Right

If you set the Edge to **<Smaller>**, TouchKit will reduce the vertical position of the right edge. If you set the Edge to **<Larger>**, TouchKit will extend the vertical position of the right edge.

In some cases, the cursor will be behind the finger when you touch the panel. If you cannot see the cursor, you can set the X Axis or Y Axis to move the cursor.

## Offset X Axis

If you set the Offset X Axis to **<Smaller>**, cursor will be moved one pixel to the left of the X Axis. If you set the Offset X Axis to **<Larger>**, cursor will be moved one pixel to the right of the X Axis.

## Offset Y Axis

If you set the Offset Y Axis to **<Smaller>**, cursor will be moved one pixel above the Y Axis. If you set the Offset Y Axis to **<Larger>**, cursor will be moved one pixel below the Y Axis.

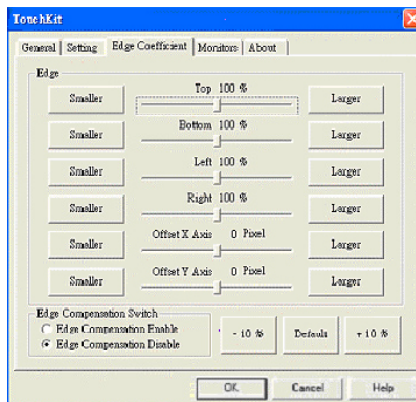

## Edge Compensation Switch

Use the **+10% and -10% button** to adjust. If you press the **+10% button**, the top, bottom, left and right edges will extend 10%, and the cursor will be moved 10 pixels from the X and Y Axis to the right and top. If you press the **-10% button**, the top, bottom, left and right edges will contract 10%, and cursor will be moved 10 pixels from the X and Y Axis to the left and bottom.

Choose the **Default button** to restore the default settings.

## 4. MONITORS: Multiple Monitors, Split Monitor

### Multiple Monitors

To configure the mapping relationship between the monitors and the touch panels, select the monitor page as below.

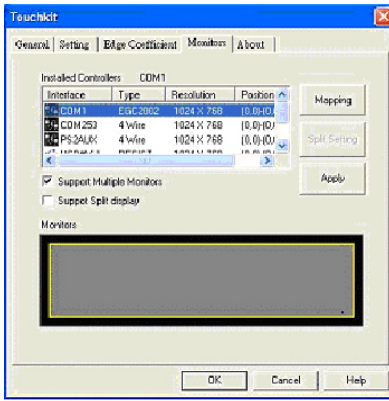

Set the check box (Use Multiple Monitors) to enable multiple monitors mapping. Unchecking this box will disable multiple-monitor configuration, and all of the touch panel controllers will be mapped to the primary monitor. The gray shadow area is the monitor mapped to the selected controller/panel. The button **[Mapping]** is used to find the mapping relationships between the monitors and touch panel controllers. Press **[Mapping]** and the software will guide you to touch the corresponding monitor to obtain the mapping relationship.



After completing monitor mapping, Press **[Apply]** to apply the mapping relationship.

### Split Monitors

To use the Split Monitor function, you need to select which controller you want to launch this function, then check the Multiple Monitors box and Split Monitor at the same time as shown below. Press the **[Split Monitor]** button to set up the active area.

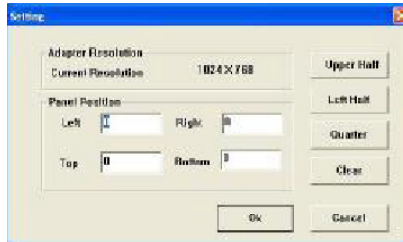

It shows the current resolution of the display and you can set the active area by inputting the value or use the default button **[Upper Half]**, **[Left Half]** or **[Quarter]**. The default value of panel resolution should be full screen as Left: **0**, Right: **0**, Top: **0** and Bottom: **0**.

5. **ABOUT:** General information about TouchKit.

### Uninstalling TouchKit

To uninstall, use the TouchKit/Uninstall from the Programs menu on the Start button.

## **Declaration of the Manufacturer**

We hereby certify that the  
TR-6001 is in compliance with

**UL  
cUL  
TUV  
FCC  
CE**

**TRANSDUCTION**  
5155 Spectrum Way Bldg 23 Mississauga, ON  
L4W 5A1  
Canada  
905-625-1907

[www.transduction.com](http://www.transduction.com)



# 2

---

## TR-980 SBC Introduction

This chapter provides information on TR-6001 single board computer, TR-980. The topics covered are as follows:

Features .....	17
Specifications .....	18-20

---

## Features

- Support Intel® Core 2 Quad, Core 2 Duo, Pentium-D, Pentium 4, Celeron D processor in LGA775 package with FSB 800M/1066/1333MHz.
- Two DDR2 1.8V DIMM sockets support up to 4GB system memory in Dual Channel Mode. System memory speed can be DDR2 800 or 667MHz.
- Six SATA ports support up to 6 SATA 3Gbps devices. Support RAID0, RAID 1, RAID 5, and RAID10.
- Dual GbE LAN design maximized the communication bandwidth for both internet and intranet connection. Root Boot and Wake Up on LAN supported.
- Multiple I/O functions: 6 x USB2.0, 2x COM ports, 6x SATA, IRDA, 1x PIDE, 1x LPT, 1x FLOPPY.
- High-Definition Audio Codec support Line-out, Line-in and Microphone, CD-IN and SPDIF.
- PICMG 1.0 Standard form factor support PCI and ISA interface.
- Multiple display technology: Support CRT, Dual channel 24-bits LVDS LCD display and DVI interface Display.

---

# Specifications

## ▪ Processor Support:

- Intel® Core 2 Quad, Core 2 Duo, Pentium-D, Pentium 4, Celeron D processor .
- Support Front Side Bus speed 800MHz, 1066MHz and 1333MHz.
- LGA775 socket

## ▪ Major Chipset:

- Intel Q35 and ICH9DO chipset.
- RealTek RTL8111C LAN chip.
- Winbond 83627HF Super I/O.
- ALC888 High-Defination Audio chip.

## ▪ System Memory:

- Two DDR2 DIMM 240pins Sockets support DDR2 667/800 unregistered non-ECC Memory up to 8.0 GB.
- Dual channel mode operation supported.

## ▪ Video Controller:

- Intel Q35 Integrated GMA3100 Graphic Engine. Support DVMT 4.0 for memory allocation up to 256MB.
- One 15-Pins D-Sub Female connector on Rear plane for CRT displays.
- One 40-pins connector support Dual channel 24-bits LVDS LCD display
- One 20-pins connector support DVI interface.
- Support Dual display CRT+LCD, CRT+DVI or DVI +LCD.

## ▪ Super I/O:

- Winbond 83627HF LPC I/F Super I/O chip.
- Two Serial ports as COM1~COM2. COM2 is RS232/422/485 selectable by jumpers.
- COM1~COM2 are pin-header for internal connections.
- One Floppy connector supports up to floppy drives.
- One Parallel port supports SPP/ECP/EPP mode.
- One IrDA port.
- One Mini-DIN connector on I/O bracket to support PS2 Keyboard and mouse.

- 
- **USB Interface:**
    - Six USB 2.0 ports compliant with USB Specification Rev. 2.0 and support USB Hot-Plug function.
    - Six ports are in three 2x5/2.54mm box header for internal USB devices connection.
    - Support Legacy USB devices and Boot from USB devices like USB-HDD, USB-Floppy and USB-CDROM.
    - All USB ports support USB type keyboard and mouse.
  - **SATA and PIDE:**
    - One PCI-E bridged PIDE controller support up to UltraDMA mode 6 or ATA133 speed.
    - One standard 40-pins Box header to support 3.5" HDD, DVD Player or DOM Flash Disk.
    - Six SATA ports support up to 6 SATA devices. Support RAID0, RAID 1, RAID 5, and RAID10. SATA RAID BIOS is integrated in System BIOS.
  - **Gigabit and 10/100M Ethernet:**
    - Two Realtek RT8111C chips on board for dual GbE LAN support.
    - Support Wake-on-LAN.
    - Remote Boot Agent is supported with PXE or RTL protocol.
  - **Audio:**
    - RealTek ALC888 High-Definition Audio chip on-board.
    - One 10-pins pin-header supports Audio Line-out. Line-In and Microphone.
    - One CD-IN to support DVD player audio input.
    - One SPDIF interface to support SPDIF digital audio input and output.
  - **PCI and ISA Slot:**
    - PICMG 1.0 Compliant design supports standard PCI and ISA bus through backplane - 2 x ISA and 4 x PCI slots.
  - **Hardware Monitor:**
    - 83627HF integrated hardware monitor chip to monitor Voltages, temperatures and FAN speed.
    - Temperature Monitor: One sensor close to CPU socket for CPU temperature detection. One sensor close to 83627HF chip for board temperature detection.
    - One CPU FAN for CPU cooler, one SYS FAN for chassis FAN. All FAN speeds are monitored.

- 
- **Watchdog Timer:**
    - The WatchDog timer can be disable/enable through BIOS setup.
    - The timeout interval 1~255 seconds can be programmed through I/O address 842h/843h. The timeout event will generate the RESET.
  - **CMOS:**
    - On-board RTC with 242 bytes of Battery-back CMOS RAM.
    - One 3-pins Jumper to clear CMOS data.
  - **BIOS:**
    - Phoenix-Award Standard PnP BIOS 6.2.
    - 8Mbit FlashROM with BootBlock for Fail-safe.
    - Enhanced ACPI and DMI2.0 compliant.
    - BIOS utility for field update.
    - VBIOS and LAN remote Boot Agent integrated.
  - **Power Connector:**
    - Support both AT mode and ATX mode operation. Selectable by jumper.
    - One Standard 4-pins power connector for standalone operation.
    - One ATX-12V 4-pins connector for CPU power input.
  - **Cooling:**
    - One CPU cooling FAN connector nearby CPU socket.
    - One System cooling FAN connectors on board for Chassis or PSU cooling.
  - **Digital Input and Output::**
    - Support 8-bits Digital I/O.
    - Software programmable to configure as 4-IN/4-OUT or 8-IN or 8-OUT.
  - **Others:**
    - One Buzzer (9mm) on-board for beep message.
  - **Operating Temperature:**
    - 0~60°C Operation Range.
    - -40C to 70C storage.
    - Relative Humidity: 5~95%, non-condensing.
  - **Dimensions:**
    - 13.3" (L) x 4.8" (W); or 338mm (L) x 124mm (W).
    - PICMG 1.0 Standard Form Factor.

# 3

---

## Installations

This chapter provides information on how to use the jumpers and connectors on the TR-980. The topics covered are as follows:

Jumpers on the TR-980 .....	22-25
Connectors on the TR-980 .....	26-41

---

## Jumper Locations on the TR-980

---

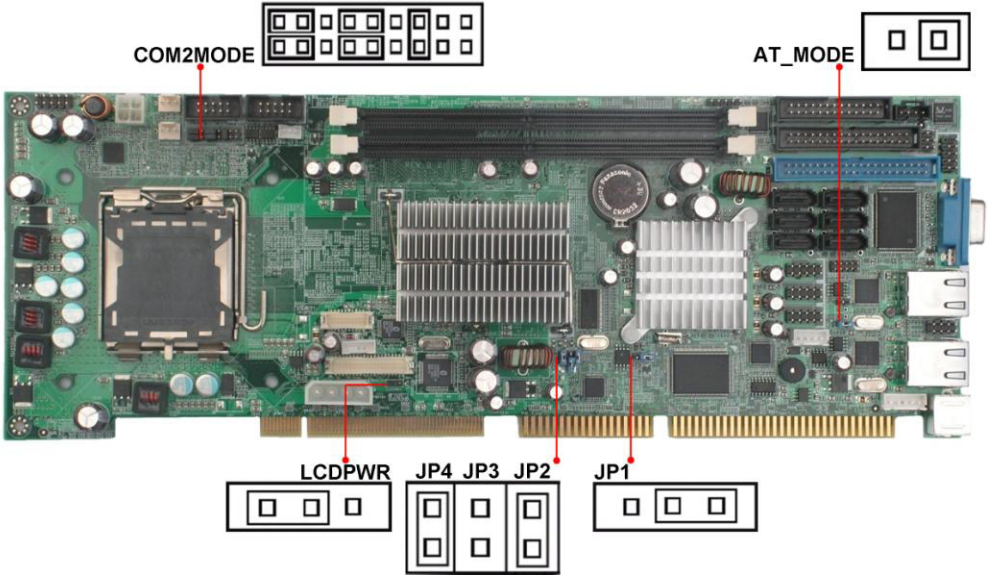

---

## JP1: Clear CMOS RAM Data

---

This 3-pin Jumper allows the user to disconnect the built-in 3V battery power to clear the information stored in the CMOS RAM. To clear the CMOS data:

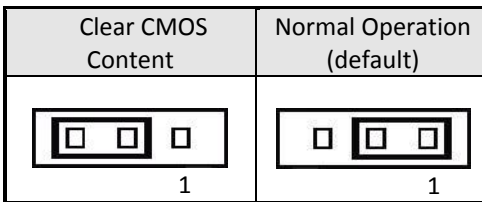

- (1) Turn off the system power.
- (2) Remove Jumper cap from pin1&2.
- (3) Short the pin2 and pin3 for three seconds.
- (4) Put Jumper cap back to pin1 & 2.
- (5) Turn on your computer.
- (6) Hold Down <Delete> during boot up and enter BIOS setup to enter your preferences.



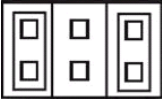
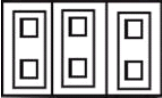

## JP2, JP3, JP4: Front Side Bus Selection

JP2 and JP3 and JP4 allow users to select the FSB speed. It can be 800 MHz, 1066 MHz or 1333 MHz.

User should select the correct FSB speed to make their CPU run on correct speed and ensure the system runs stably.

JP2~JP4	Setting	Speed
<p style="text-align: center;">1    1    1</p>  <p style="text-align: center;">JP4   JP3   JP2</p>	<p>JP2: Pin 1-2 short JP4: Pin 1-2 short</p>	800Mhz FSB (default)
<p style="text-align: center;">1    1    1</p>  <p style="text-align: center;">JP4   JP3   JP2</p>	<p>JP2: Pin 1-2 short JP3: Pin 1-2 short JP4: Pin 1-2 short</p>	1066Mhz FSB
<p style="text-align: center;">1    1    1</p>  <p style="text-align: center;">JP4   JP3   JP2</p>	<p>JP2: Pin 1-2 short JP3: Pin 1-2 short</p>	1333Mhz FSB

## AT\_MODE: Power Supply Mode Selection

AT mode (default)	ATX mode
<p style="text-align: center;">1</p>  <p style="text-align: center;">AT_MODE</p>	<p style="text-align: center;">1</p>  <p style="text-align: center;">AT_MODE</p>

---

## COM2MODE: RS232/RS422/RS485

---

COM2 support multi-protocols include RS232, RS422 and RS485.

The Protocols of COM2 can be set up through jumpers.

COM2MODE: COM2 Protocols selection.

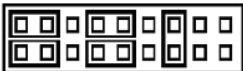
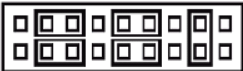
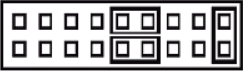

The pin-out for each mode is illustrated on next chapter.

COM2MODE		I/F TYPE
17	1	RS-232 (default)
		
18	2	RS-422
17	1	
		
18	2	RS-485
17	1	
		
18	2	

## LCDPWR: LCD PANEL Power Selection

---

LCDPWR can be used to select the Panel LCD supple power: +3.3V or +5V. The default setting is on +3.3V. User need to check the LCD panel spec and adjust this jumper to make Panel work in specified power rail. This Jumper serves LVDS LCD connector.

+5V	+3.3V(default)
	
1	1

## Connector Locations on the TR-980

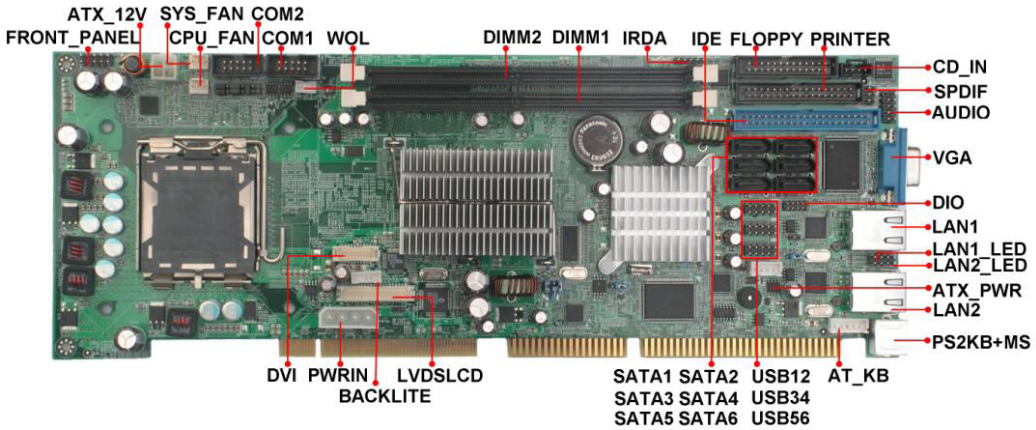

---

## DIO Connector

---

DIO ports support 8 digital I/O bits. Each bit can be configured as Input or output individually. All bits are 5V tolerant.

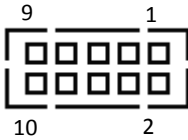

Signal Name	Pin #	Pin #	Signal Name
GND	1	2	+5V
DIO_0	3	4	DIO_4
DIO_1	5	6	DIO_5
DIO_2	7	8	DIO_6
DIO_3	9	10	DIO_7

## USB12, 34, 56 Connectors

---

The following table shows the pin outs of the USB12, USB34, USB56 connectors.

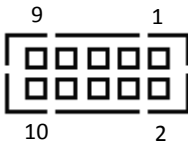

Signal Name	Pin #	Pin #	Signal Name
N.C.	1	2	VCC
GND	3	4	USB-
USB+	5	6	USB+
USB-	7	8	GND
VCC	9	10	N.C.

## SATA1~6 Connectors

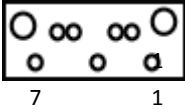

Pin #	Signal Name
1	GND
2	SATATX+
3	SATATX-
4	GND
5	SATARX-
6	SATARX+
7	GND

## VGA Connector

The pin assignments of VGA CRT connector are as follows:

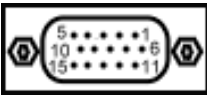

Signal Name	Pin #	Pin #	Signal Name
Red	1	2	Green
Blue	3	4	N.C.
GND	5	6	GND
GND	7	8	GND
N.C.	9	10	GND
N.C.	11	12	DDC_DATA
HSYNC	13	14	VSYNC
DDC_CLK	15		

---

## LAN1, 2- RJ45 Connectors

---

This connector is for the 10/100/1000Mbps Ethernet capability. The figure below shows the pin out assignments of this connector and its corresponding input jack.

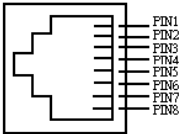

Pin #	Signal Name
1	MDI0+
2	MDI0-
3	MDI1+
4	MDI1-
5	MDI2+
6	MDI2-
7	MDI3+
8	MDI3-

---

## LAN RJ45 LED1, 2

---

The LAN\_LEDs on top of RJ45 are to display the current network connection status. The green color LED on the right-hand side shows the link status and TX/RX activity. The Orange/Green Dual color LED on the left-hand side indicates the operation mode, i.e. 10Base-T, 100Base-T or 1000Base-T.

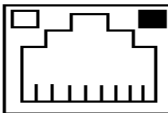

LNK/ACT	STATUS
GREEN	Link
OFF	Disconnected
FLASH	Packets TX/RX

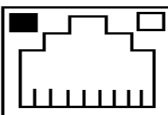

SPEED	MODE
ORANGE	1000 Mbps
GREEN	100 Mbps
OFF	10 Mbps

---

## AUDIO Connector

---

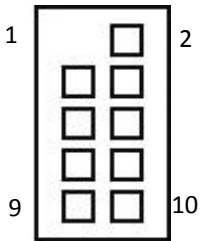

Pin #	Signal Name
1	KEY
2	NC
3	MIC1-IN-L
4	MIC1-IN-R
5	AGND
6	AGND
7	LINEOUT-L
8	LINE-IN-L
9	LINEOUT-R
10	LINE-IN-R

## CD\_IN Connector

---

CD\_IN connector is designed for wire the CD\_ROM audio signals to the on-board Audio CODEC.

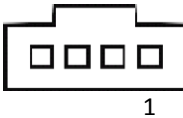

Pin #	Signal Name
1	CD_Left
2	GND
3	GND
4	CD_Right

## PS/2 Keyboard & Mouse Connector

The following table describes the pin assignment of PS/2 Keyboard and Mouse connector, which is mounted on a button of a bracket. To attach PS/2 Keyboard and mouse, users need to connect through a PS/2 1-to-2 Y-cable and plug into this Mini-Din connector. All the PISA-E11 boards come with a Y-cable. Contact with your dealer if the Y-cable is missing.

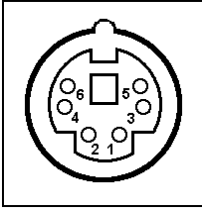

Pin #	Signal Name
1	Keyboard data
2	Mouse data
3	GND
4	5V
5	Keyboard clock
6	Mouse clock

## FRONT\_PANEL Connector

The front panel of the case has a control panel, which provides light indication of the computer activities and switches to change the computer status.

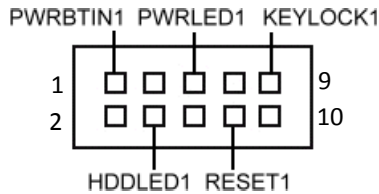

### ➤ PWRBTN1 (ATX Power ON/OFF Button)

This 2-pin connector acts as the "Power Supply On/Off Switch" on the TR-980 main board. When pressed, the switch will force the Main board to power on. When pressed again, it will force the main board to power off.

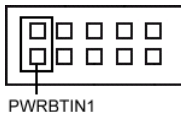

PWRBTN Pin #	Signal Name
1	5VSB
2	PWRBTN

➤ **HDDLED1 (IDE Hard Disk LED Connector)**

This connector connects to the hard drive activity LED on control panel. This LED will flash when the HDD is being accessed.

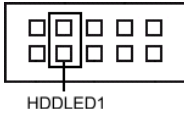

HDDLED Pin #	Signal Name
3	VCC
4	HDDLED

➤ **PWRLED1 (Power-On LED)**

This connector allows users to connect to Front Panel Power indicator.

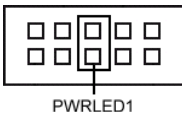

PWR LED Pin #	Signal Name
5	PWRLED
6	Ground

➤ **RESET1**

The reset switch allows the user to reset the system without turning the main power switch off and then on. Orientation is not required when making a connection to this header.

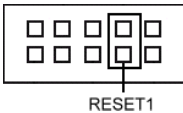

RESET1 Pin #	Signal Name
7	SYS_RST
8	Ground

➤ **KEYLOCK Switch**

The keylock switch, when closed, will disable the keyboard function.

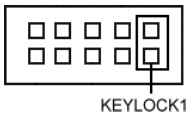

RESET Pin #	Signal Name
9	KEYLOCK
10	NC

---

## System FAN Connector

---

This is a 3-pin header for the system fan.

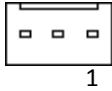

Pin #	Signal Name
1	Ground
2	+12V
3	SYSPWM

---

## CPU FAN Connector

---

This is a 3-pin header for the CPU fan.

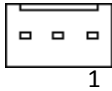

Pin #	Signal Name
1	Ground
2	+12V
3	CPUPWM

---

## IRDA Connector

---

This connector is used for an IrDA connector for wireless communication.



IrDA Pin #	Signal Name
1	+5V
2	FIR
3	IR-RX
4	Ground
5	IR-TX

---

## COM1 Serial Port

---

COM1, a 10-pins box-header connector, is the onboard COM1 serial port of the TR-980. The following table shows its pin assignments.

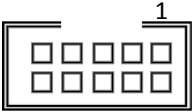

Pin #	Signal Name
1	DCD, Data carrier detect
2	RXD, Receive data
3	TXD, Transmit data
4	DTR, Data terminal ready
5	GND, ground
6	DSR, Data set ready
7	RTS, Request to send
8	CTS, Clear to send
9	+5V, Ring-IN or +12V
10	NC

---

## COM2 Serial Port

---

COM2, a 10-pins box-header connector, is the onboard COM2 serial port of the TR-980. The following table shows its pin assignments.

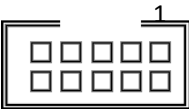

Pin #	RS232 Mode Signal Name	RS422/RS485 Mode Signal Name
1	DCD, Data carrier detect	TX- (422/485)
2	RXD, Receive data	TX+ (422/485)
3	TXD, Transmit data	RX+ (422)
4	DTR, Data terminal ready	RX- (422)
5	GND, ground	GND
6	DSR, Data set ready	N.C.
7	RTS, Request to send	N.C.
8	CTS, Clear to send	N.C.
9	+5V, Ring-IN or +12V	N.C.
10	N.C.	N.C.

## IDE Connector

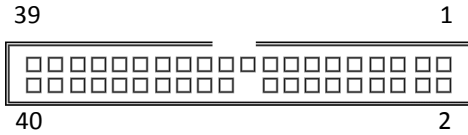

Signal Name	Pin #	Pin #	Signal Name
Reset IDE	1	2	Ground
Host data 7	3	4	Host data 8
Host data 6	5	6	Host data 9
Host data 5	7	8	Host data 10
Host data 4	9	10	Host data 11
Host data 3	11	12	Host data 12
Host data 2	13	14	Host data 13
Host data 1	15	16	Host data 14
Host data 0	17	18	Host data 15
Ground	19	20	Key
DRQ	21	22	Ground
Host IOW	23	24	Ground
Host IOR	25	26	Ground
IOCHRDY	27	28	Host PU 0
DACK	29	30	Ground
IRQ14	31	32	No connect
Address 1	33	34	P66DET
Address 0	35	36	Address 2
Chip select 1	37	38	Chip select 3
Activity LED	39	40	GND

## LAN1\_LED Connector

The 4-pins LAN1\_LED connector designed for LAN1 port is for applications need to display LAN1 port status on front panel or the places administrators are easy to access.

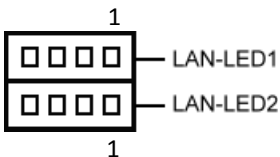

Pin #	Signal Name
1	1_ACTLED
2	1_PULUP
3	1_LINK1000
4	1_LINK100

---

## LAN2\_LED Connector

---

The 4-pins LAN2\_LED connector designed for LAN2 port is for applications need to display LAN2 port status on front panel or the places administrators are easy to access.



Pin #	Signal Name
1	2_ACTLED
2	2_PULUP
3	2_LINK1000
4	2_LINK100

---

## SPDIF Connector

---

SPDIF connector is for S/PDIF audio module that allows digital instead of analog sound input or output.

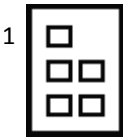

Signal Name	Pin	Pin	Signal Name
VCC	1	2	NC
SPDIFO	3	4	SPDIFI
GND	5	6	GND

---

## ATX\_12V Connector

---

The ATX\_12V power connector mainly supplies power to the CPU.

Caution!

If the ATX\_12V power connector is not connected, the system will not start.

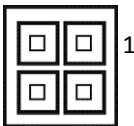

ATX\_12V

Pin #	Signal Name
1	GND
2	GND
3	+12V
4	+12V

---

## Floppy Drive Connector

---

Floppy connector is a 34-pin header and will support up to 2.88MB floppy drives.

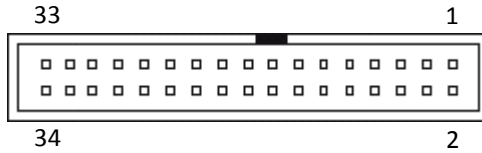

Signal Name	Pin #	Pin #	Signal Name
Ground	1	2	RM/LC
Ground	3	4	No connect
Ground	5	6	No connect
Ground	7	8	Index
Ground	9	10	Motor enable 0
Ground	11	12	Drive select 1
Ground	13	14	Drive select 0
Ground	15	16	Motor enable 1
Ground	17	18	Direction
Ground	19	20	Step
Ground	21	22	Write data
Ground	23	24	Write gate
Ground	25	26	Track 00
Ground	27	28	Write protect
Ground	29	30	Read data
Ground	31	32	Side 1 select
Ground	33	34	Diskette change

---

## WOL Connector

---



Pin #	Signal Name
1	5VSB
2	GND
3	RI-

---

## PRINTER Connector

---

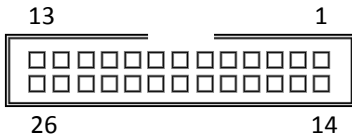

Signal Name	Pin #	Pin #	Signal Name
Line printer strobe	1	14	AutoFeed
PD0, parallel data 0	2	15	Error
PD1, parallel data 1	3	16	Initialize
PD2, parallel data 2	4	17	Select
PD3, parallel data 3	5	18	Ground
PD4, parallel data 4	6	19	Ground
PD5, parallel data 5	7	20	Ground
PD6, parallel data 6	8	21	Ground
PD7, parallel data 7	9	22	Ground
ACK, acknowledge	10	23	Ground
Busy	11	24	Ground
Paper empty	12	25	Ground
Select	13	26	N/A

## DVI Connector

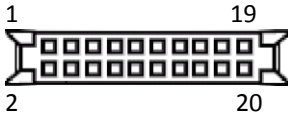

Signal Name	Pin #	Pin #	Signal Name
TCLK+	1	2	TDC1+
TCLK-	3	4	TDC1-
GND	5	6	GND
TDC0+	7	8	TDC2+
TDC0-	9	10	TDC2-
GND	11	12	GND
NC	13	14	NC
CLOCK	15	16	DATA
DVI_PLUG	17	18	GND
VCC	19	20	VCC

## BACKLITE Connector

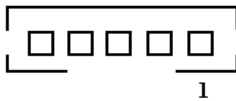

Pin #	Signal Name
1	+12V
2	GND
3	Brightness
4	ON/OFF
5	GND

## LVDSLCD Connector

The LCD panel, inverter for LCD LAMP, Touch-screen Serial Interface must be connected to this LVDS header, using the below described connector:



Signal Name	Pin #	Pin #	Signal Name
+12V	1	2	+12V
GND	3	4	GND
LCDVDD 5V/3.3V	5	6	LCDVDD 5V/3.3V
GND	7	8	GND
BRIGHTNES	9	10	BCKLITE_ON
LVDS_GND	11	12	LVDS_GND
CHA_TX0+	13	14	CHB_TX0+
CHA_TX0-	15	16	CHB_TX0-
LVDS_GND	17	18	LVDS_GND
CHA_TX1+	19	20	CHB_TX1+
CHA_TX1-	21	22	CHB_TX1-
LVDS_GND	23	24	LVDS_GND
CHA_TX2+	25	26	CHB_TX2+
CHA_TX2-	27	28	CHB_TX2-
LVDS_GND	29	30	LVDS_GND
CHA_TXC+	31	32	CHB_TXC+
CHA_TXC-	33	34	CHB_TXC-
LVDS_GND	35	36	LVDS_GND
CHA_TX3+	37	38	CHB_TX3+
CHA_TX3-	39	40	CHB_TX3-

---

## AT\_KB Connector

---



Pin #	Signal Name
1	KBCLK
2	KBDAT
3	PWOK
4	GND
5	KBVCC

---

## ATX\_PWR

---

This is a four-pin connector to supports the ATX power and corresponding back-plane. When your back-plane is configured to perform ATX power supply Soft-on/off function, you have to connect the control signals and stand-by power on this connector to your back-plane by a corresponding cable.

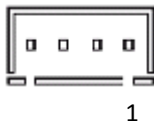

Pin #	Signal Name
1	PWOK
2	5VSB
3	PS_ON-
4	GND

When using ATX power supply soft-on/off function, please make sure remove AT\_MODE jumper.

The setting is illustrated as below:

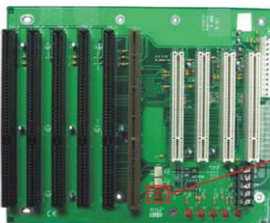

BACKPLANE



CABLE

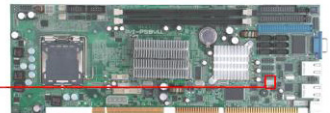

TR-980

# 4

---

## BIOS Setup

This chapter describes the different settings available on the Award BIOS that comes with TR-980. The topics covered are as follows:

Main Menu .....	43-45
Standard CMOS Features .....	46-51
Advanced BIOS Features .....	52-58
Advanced Chipset Features .....	59-62
Integrated Peripherals .....	63-71
Power Management Setup .....	72-77
PnP/PCI Configuration .....	78-82
PC Health Status .....	83-84
Load Fail-Safe Defaults .....	85
Load Optimized Defaults .....	85
Set Supervisor/User Password .....	86-87
Save & Exit Setup .....	88
Exit Without Saving .....	88

---

## **BIOS Introduction**

---

This manual describes Award's Setup program, which is built into the ROM BIOS. The Setup program allows users to modify the basic system configuration. This special information is then stored in battery-backed RAM so that it retains the Setup information when the power is turned off.

### **Starting Setup**

---

The following pages are meant to give you a better insight into the options you have to setup your system.

Many options depend on the choice of type of memory, memory speed, peripherals and the programs that you will be running.

The effective of these settings are related to system performance that can destabilize operation.

We urge you to proceed with caution.

When the system is powered on, use the bios set program when you start up your system, reconfiguring your system, or press "Delete" promptly to run setup.

This section will explain how to configure your system using this utility.

And this change will be recognized and record them in the CMOS RAM of the SPI chip.

When you start up the computer, the system provides you the opportunity to set the program.

Press the "del" during the P.O.S.T (Power-on Self-Test) to enter the program setting.

And the POST will continue with the test routines.

And the firmware chip will store the setup utility on the board.

However, if you want to enter the setup after the POST, you can press Ctrl + Alt + Del simultaneously or turn off the power then back on.



---

### ➤ **Integrated Peripherals**

---

Use this menu to specify your settings for integrated peripherals.

### ➤ **Power Management Setup**

---

Use this menu to specify your settings for power management.

### ➤ **PnP/PCI Configurations**

---

Use this menu to set up the PnP/PCI configuration.

### ➤ **PC Health Status**

---

Use this menu to display the CPU temperature, FAN speed and voltages.

### ➤ **Load Fail-Safe Defaults**

---

Use this menu to load the BIOS default values for the minimal/stable performance for your system to operate.

### ➤ **Load Optimized Defaults**

---

Use this menu to load the BIOS default values that are factory settings for optimal performance system operations. While Award has designed the custom BIOS to maximize performance, the factory has the right to change these defaults to meet their needs.

### ➤ **Set Supervisor/ User Password**

---

Use this menu to set User and Supervisor Passwords.

### ➤ **Save & Exit Setup**

---

Save CMOS value changes to CMOS and exit setup.

### ➤ **Exit Without Saving**

---

Abandon all CMOS value changes and exit setup.

## 4.2 Standard CMOS Features

The items in Standard CMOS Setup Menu are divided into 10 categories. Each category includes no, one or more than one setup items. Use the arrow keys to highlight the item and then use the <PgUp> or <Pg Dn> keys to select the value you want in each item.

Phoenix-Award BIOS CMOS Setup Utility Standard CMOS Features		
Date (mm :dd: yy)	Fri, Sep 25 2008	Item Help  Menu Level ▶  Change the day, month, year, and century
Time (hh: mm: ss)	15 : 35 : 35	
▶ IDE Channel 0 Master	[None]	
▶ IDE Channel 0 Slave	[None]	
▶ IDE Channel 1 Master	[None]	
▶ IDE Channel 1 Slave	[None]	
▶ IDE Channel 2 Master	[None]	
▶ IDE Channel 3 Master	[None]	
▶ IDE Channel 4 Master	[None]	
▶ IDE Channel 4 Slave	[None]	
Drive A	[1.44M, 3.5 in.]	
Drive B	[None]	
Video	[EGA/VGA]	
Halt On	[All , But Disk/Key]	
Base Memory	639K	
Extend Memory	513024K	
Total Memory	514048K	
↑ ↓ ← → : Move    Enter: Select    +/-/PU/PD: Value    F10:Save    Esc: Exit F1:General Help    F5:Previous Value    F6:Fail-Safe Defaults    F7:Optimized Default		

(Figure 2)

This table shows the selections that you can make on the Standard CMOS Menu.

Item	Options	Description
Date	Month DD YYYY	Set the system date. Note that the 'Day' automatically changes when you set the date
Time	HH : MM : SS	Set the system time
IDE Channel 0 Master	Options are in its sub menu	Press <Enter> to enter the sub menu of detailed options
IDE Channel 0 Slave	Options are in its sub menu	Press <Enter> to enter the sub menu of detailed options
IDE Channel 1 Master	Options are in its sub menu	Press <Enter> to enter the sub menu of detailed options
IDE Channel 1 Slave	Options are in its sub menu	Press <Enter> to enter the sub menu of detailed options
IDE Channel 2 Master	Options are in its sub menu	Press <Enter> to enter the sub menu of detailed options
IDE Channel 3 Master	Options are in its sub menu	Press <Enter> to enter the sub menu of detailed options
IDE Channel 4 Master	Options are in its sub menu	Press <Enter> to enter the sub menu of detailed options
IDE Channel 4 Slave	Options are in its sub menu	Press <Enter> to enter the sub menu of detailed options
Drive A Drive B	None 360K, 5.25 in 1.2M, 5.25 in 720K, 3.5 in 1.44M, 3.5 in 2.88M, 3.5 in	Select the type of floppy disk drive installed in your system
Video	EGA/VGA CGA 40 CGA 80 MONO	Select the default video device
Halt On	All Errors No Errors All, but Keyboard All, but Diskette All, but Disk/Key	Select the situation in which you want the BIOS to stop the POST process and notify you
Base Memory	N/A	Displays the amount of conventional memory detected during boot up
Extended Memory	N/A	Displays the amount of extended memory detected during boot up
Total Memory	N/A	Displays the total memory available in the system

## ➤ IDE Channel 0, 1 Master/ Slave

The IDE adapters control the hard disk drive. Use a separate sub menu to configure each hard disk drive. Figure 3 shows the IDE Channel 0 / Channel 1 master sub menu.

Phoenix-Award BIOS CMOS Setup Utility IDE Channel 0 Master		
IDE HDD Auto-Detection	[Press Enter]	Item Help
IDE Channel 0 Master Access Mode	[Auto] [Auto]	Menu Level ▶
Capacity	0 MB	To auto-detect the HDD's size, head...on this channel
Cylinder	0	
Head	0	
Precomp	0	
Landing Zone	0	
Sector	0	
↑ ↓ ← → : Move    Enter: Select    +/-/PU/PD: Value    F10:Save    Esc: Exit    F1:General Help F5:Previous Value    F6:Fail-Safe Defaults    F7:Optimized Default		

**(Figure 3)**

---

## ➤ IDE Channel 2, 3, 4 Master/ Slave

---

Figure 4 shows the IDE Channel 2 / Channel 3 master sub menu.

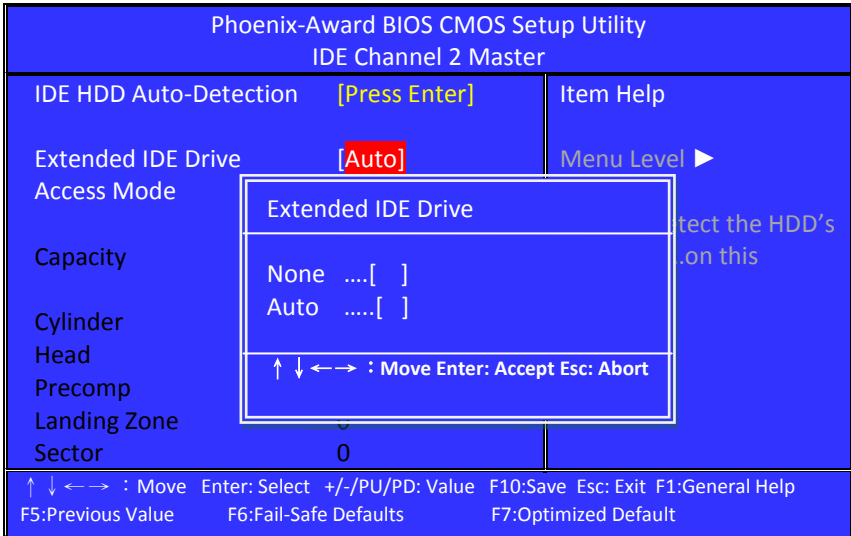

(Figure 4)

### Extended IDE Drive

---

The choice: None, Auto (**default**)

Use the legend keys to navigate through this menu and exit to the main menu. Use the Table listed below to configure the hard disk.

Item	Options	Description
IDE HDD Auto-detection	Press Enter	Press Enter to auto-detect the HDD on this channel. If detection is successful, it fills the remaining fields on this menu.
IDE Channel 0 Master	None Auto Manual	Selecting 'manual' lets you set the remaining fields on this screen. Selects the type of fixed disk. "User Type" will let you select the number of cylinders, heads, etc. Note: PRECOMP=65535 means NONE!
Access Mode	CHS LBA Large Auto	Choose the access mode for this hard disk
Capacity	Auto Display your disk drive size	Disk drive capacity (Approximated). Note that this size is usually slightly greater than the size of a formatted disk given by a disk checking program.
The following options are selectable only if the 'IDE Channel 0 Master' item is set to 'Manual'		
Cylinder	Min = 0 Max = 65535	Set the number of cylinders for this hard disk.
Head	Min = 0 Max = 255	Set the number of read/write heads
Precomp	Min = 0 Max = 65535	**** Warning: Setting a value of 65535 means no hard disk
Landing zone	Min = 0 Max = 65535	****
Sector	Min = 0 Max = 255	Number of sectors per track

---

## Drive A/B

---

These fields identify the types of floppy disk drive A or drive B that has been installed in the computer. The available specifications are:

None	360K	1.2M	720K	1.44M	2.88M
	5.25 in.	5.25 in.	3.5 in.	3.5 in.	3.5 in.

**(default)**

## Video

---

This field selects the type of video display card installed in your system.

You can choose the following video display cards:

EGA/VGA: For EGA, VGA, SEGA, SVGA or PGA monitor adapters.

**(default)**

CGA 40: Power up in 40 column mode.

CGA 80: Power up in 80 column mode.

MONO: For Hercules or MDA adapters.

## Halt On

---

This field determines whether the system will halt if an error is detected during power up.

All errors	Whenever the BIOS detects a non-fatal error, the system will stop and you will be prompted.
No errors	The system boot will not be halted for any error that may be detected.
All, But Keyboard	The system boot will not be halted for a keyboard error; it will stop for all other errors
All, But Diskette	The system boot will not be halted for a disk error; it will stop for all other errors.
All, But Disk/Key	The system boot will not be halted for a keyboard or disk error; it will stop for all others. <b>(default)</b>

## 4.3 Advanced BIOS Features

This section allows you to configure your system for basic operation. You have the opportunity to select the system's default speed, boot-up sequence, keyboard operation, shadowing and security.

Phoenix-Award BIOS CMOS Setup Utility		
Advanced BIOS Features		
▶ CPU Features	[Press Enter]	Item Help
▶ Hard Disk Boot Priority	[Press Enter]	Menu Level ▶
Virus Warning	[Disabled]	
Hyper-Threading Technology	[Enabled]	
Quick Power On Self Test	[Enabled]	
First Boot Device	[Hard Disk]	
Second Boot Device	[CDROM]	
Third Boot Device	[LS120]	
Boot Other Device	[Enabled]	
Swap Floppy Drive	[Disabled]	
Boot Up Floppy Seek	[Enabled]	
Boot UP Num Lock Status	[Off]	
Gate A20 Option	[Fast]	
Typematic Rate Setting	[Disabled]	
x Typematic Rate (Chars/Sec)	6	
x Typematic Delay (Msec)	250	
Security Option	[Setup]	
X APIC Mode	[Enabled]	
MPS Version Control For OS	[1.4]	
OS Select For DRAM > 64MB	[Non-OS2]	
Report No FDD For WIN 95	[No]	
↑ ↓ ← → : Move Enter: Select +/-/PU/PD: Value F10:Save Esc: Exit F1:General Help F5:Previous Value F6:Fail-Safe Defaults F7:Optimized Default		

(Figure 5)

---

## ➤ CPU Feature

---

Phoenix-Award BIOS CMOS Setup Utility		
CPU Feature		
PPM Mode	[Native Mode]	Item Help
Limit CPUID Max Val	[Disabled]	
C1E Function	[Auto]	Menu Level ▶
Execute Disabled Bit	[Enabled]	

↑ ↓ ← → : Move Enter: Select +/-/PU/PD: Value F10:Save Esc: Exit  
F1:General Help F5:Previous Value F6:Fail-Safe Defaults F7:Optimized Default

(Figure 6)

### PPM Mode

The choice: Native Mode (**default**), SMM Mode.

### Limit CPUID Max Val

The choice: Enabled, Disabled (**default**).

### C1E Function

The choice: Auto (**default**), Disabled.

### Execute Disabled Bit

The choice: Enabled, Disabled (**default**).

---

## ➤ Hard Disk Boot Priority

---

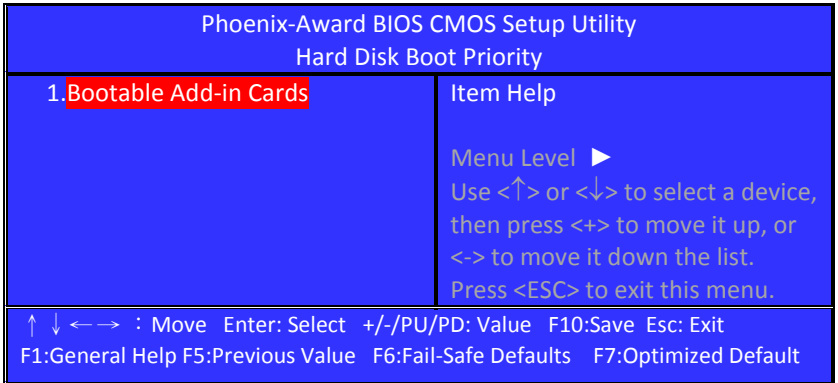

(Figure 7)

### Bootable Add-in Cards

---

This is for setting the priority of the hard disk boot order when the "Hard Disk" option is selected in the "[First/Second/Third] Boot Device" menu item.

---

## Virus Warning

---

Allows you to choose the VIRUS Warning feature for IDE Hard Disk boot sector protection.

If this function is enabled and someone attempt to write data into this area, BIOS will show a warning message on screen and alarm beep.

Enabled	Activates automatically when the system boots up causing a warning message to appear when anything attempts to access the boot sector or hard disk partition table.
Disabled	No warning message will appear when anything attempts to access the boot sector or hard disk partition table. <b>(default)</b>

## Hyper-Threading Technology

---

This field is used to enable the functionality of the Intel® Pentium® 4 Processor with Hyper-Threading Technology and will appear only when using this processor.

The choice: Enabled **(default)**, Disabled.

## Quick Power On Self Test

---

Allows the system to skip certain tests while booting. This will decrease the time needed to boot the system.

Enabled	Enable quick POST <b>(default)</b>
Disabled	Normal POST

## First/Second/Third Boot Device

---

The BIOS attempts to load the operating system from the devices in the sequence selected in these items.

The Choice: Floppy, LS120, Hard-Disk, ZIP100, CDROM, Disabled, USB-FDD, USB-ZIP, USB-CDROM, Legacy LAN.

Item	Default
First Boot Device	Hard-Disk
Second Boot Device	CDROM
Third Boot Device	LS120

---

## Boot Other Device

---

When enabled, BIOS will try to load the operating system from other device when it failed to load from the three devices above.  
The choice: Enabled (**default**), Disabled.

## Swap Floppy Drive

---

If the system has two floppy drives, choose "Enabled" to assign physical drive B to logical drive A and vice-versa.  
The choice: Enabled, Disabled (**default**).

## Boot Up Floppy Seek

---

Selection of the command 'Disabled' will speed the boot up.  
Selection of 'Enabled' Searches disk drives during boot up.  
The choice: Enabled (**default**), Disabled.

## Boot Up Num Lock Status

---

Selects power on state for Num Lock.  
The choice: On, Off (**default**).

## Gate A20 Option

---

The choice:  
Normal: A pin in the keyboard controller controls GateA20.  
Fast (**default**): Lets chipset control GateA20.

## Typematic Rate Setting

---

Keystrokes repeat at a rate determined by the keyboard controller.  
When enabled, the typematic rate and typematic delay can be selected.  
The choice: Enabled, Disabled (**default**).

If Typematic Rate Setting is [Enabled], can choice Rate and Delay:

---

## Typematic Rate (Chars/Sec)

---

Sets the number of times a second to repeat a keystroke when you hold the key down.

The choice: 6 (**default**), 8, 10, 12, 15, 20, 24, 30.

Typematic Rate (Chars/Sec)	
6	..... [ <input type="checkbox"/> ]
8	..... [ ]
10	..... [ ]
12	..... [ ]
15	..... [ ]
20	..... [ ]
24	..... [ ]
30	..... [ ]
↑↓: Move Enter: Accept ESC: Abort	

## Typematic Delay (Msec)

---

Sets the delay time after the key is held down before it begins to repeat the keystroke.

The choice: 250 (**default**), 500, 750, and 1000.

Typematic Delay (Msec)	
250	..... [ <input type="checkbox"/> ]
500	..... [ ]
750	..... [ ]
1000	..... [ ]
↑↓: Move Enter: Accept ESC: Abort	

---

## Security Option

---

Select whether the password is required every time the system boots or only when you enter setup.

System	The system will not boot and access to Setup will be denied if the correct password is not entered at the prompt.
Setup	The system will boot, but access to Setup will be denied if the correct password is not entered at the prompt. <b>(default)</b>

Note: To disable security, select PASSWORD SETTING at Main Menu and then you will be asked to enter password.

Do not type anything and just press <Enter>, it will disable security.

Once the security is disabled, the system will boot and you can enter Setup freely.

---

## APIC Mode

---

This setting allows to enable the APIC mode.

The choice: Enabled **(default)**, Disabled.

---

## MPS Version Control For OS

---

The BIOS supports version 1.1 and 1.4 of the Intel multiprocessor specification.

Select version supported by the operation system running on this computer.

The choice: 1.1, 1.4 **(default)**.

---

## OS Select For DRAM > 64MB

---

Select OS2 only if you are running OS/2 operating system with greater than 64MB of RAM on the system.

The choice: Non-OS2 **(default)**, OS2.

---

## Report No FDD For WIN 95

---

The choice: No **(default)**, Yes.

## 4.4 Advanced Chipset Features

This section allows you to configure the system based on the specific features of the installed chipset.

This chipset manages bus speeds and access to system memory resources, such as DRAM and the external cache.

It also coordinates communications between the conventional ISA bus and the PCI bus.

It must be stated that these items should never need to be altered.

The default settings have been chosen because they provide the best operating conditions for your system.

The only time you might consider making any changes would be if you discovered that data was being lost while using your system.

Phoenix-Award BIOS CMOS Setup Utility Advanced Chipset Features			
DRAM Timing Selectable	[By SPD]	Item Help	
x CAS Latency Time	[Auto]	Menu Level ▶	
x Dram RAS# to CAS# Delay	[Auto]		
x DRAM RAS# Precharge	[Auto]		
x Precharge dealy (tRAS)	[Auto]		
x System Memory Frequency	[By SPD]		
System BIOS Cacheable	[Enabled]		
Memory Hole At 15M-16M	[Disabled]		
▶ PCI Express Root Port Func	[Press Enter]		
<b>**VGA Setting**</b>			
On-Chip Frame Buffer Size	[ 8MB]		
DVMT Mode	[DVMT]		
DVMT / FIXED Memory Size	[128MB]		
Boot Display	[3]		
Lan1 Chip Control	[Enabled]		
Lan2 Chip Control	[Enabled]		
↑ ↓ ← → : Move Enter: Select +/-/PU/PD: Value F10:Save Esc: Exit F1:General Help F5:Previous Value F6:Fail-Safe Defaults F7:Optimized Default			

(Figure 8)

---

## DRAM Timing Selectable

---

The choice: Manual, By SPD (**default**).

If DRAM Timing Selectable is [**Manual**], can choice these Items:

- ▶ CAS Latency Time.
- ▶ Dram RAS# to CAS# Delay.
- ▶ DRAM RAS# Precharge.
- ▶ Precharge dealy (tRAS).
- ▶ System Memory Frequency.

---

## CAS Latency Time

---

This controls the latency between DDR RAM read command and the time that the data actually becomes available.

Leave this on the default setting.

The choice: 5, 4, 3, 6, Auto (**default**).

---

## DRAM RAS# to CAS# Delay

---

In order to improve performance, certain space in memory is reserved for PISA cards.

This memory must be mapped into the memory space below 16MB.

The choice: 2, 3, 4, 5, 6, Auto (**default**).

---

## DRAM RAS# Precharge

---

This controls the idle clocks after issuing a precharge command to DRAM.

Leave this on the default setting.

The choice: Auto (**default**), 2, 3,4,5,6.

---

## Precharge dealy (tRAS)

---

The choice: Auto (**default**), 4,5,6,7,8,9,10,11,12,13,14,15.

---

## System Memory Frequency

---

The choice: Auto (**default**), 533MHz, 667MHz.

---

## System BIOS Cacheable

---

The choice: Enabled (**default**), Disabled.

---

## Memory Hole At 15M-16M

---

Enabling this feature reserves 15 MB to 16 MB memory address space for ISA expansion cards that specifically require this setting. This makes memory from 15 MB and up unavailable to the system. Expansion cards can only access memory up to 16 MB.  
The choice: Enabled, Disabled **(default)**

## ➤ PCI Express Root Port Func

---

The choice: [Press Enter].

Phoenix-Award BIOS CMOS Setup Utility		Item Help
PCI Express Root Port Func		
PCI Express Port 1	[Disabled]	Menu Level ▶
x PCI Express Port 2	[Disabled]	
x PCI Express Port 3	[Disabled]	
x PCI Express Port 4	[Disabled]	
x PCI Express Port 5	[Disabled]	
x PCI Express Port 6	[Disabled]	
x PCI-E Compliancy Mode	[v1.0a]	
↑ ↓ ← → : Move Enter: Select +/-/PU/PD: Value F10:Save Esc: Exit F1:General Help F5:Previous Value F6:Fail-Safe Defaults F7:Optimized Default		

## PCI Express Port 1, 2, 3, 4, 5, 6

---

The choice: Auto **(default)**, Enabled, Disabled.

## PCI-E Compliancy Mode

---

The choice: v1.0a **(default)**, v1.0.

## On-Chip Frame Buffer Size

---

User can select frame buffer size.  
The choice: 1MB, 8MB **(default)**.

## DVMT Mode

---

This field shows the current DVMT mode.  
The choice: FIXED, DVMT **(default)**, BOTH.

---

## DVMT / FIXED Memory Size

---

This field is used to select the graphics memory size used by DVMT/Fixed mode.

The choice: 64MB, 128MB (**default**), 224MB.

## Boot Display

---

This field is used to select the type of display to use when the system boots.

The choice: Auto (**default**), CRT, TV, EFP, LFP, CRT+LFP, ERP+LFP.

## Panel Number

---

These fields allow you to select the LCD Panel type.

The choice: 1~16. 3(**default**)

## Lan1 Chip Control

---

The choice: Enabled (**default**), Disabled.

## Lan2 Chip Control

---

The choice: Enabled (**default**), Disabled.

## 4.5 Integrated Peripherals

Phoenix-Award BIOS CMOS Setup Utility Integrated Peripherals		
▶ On Chip IDE Device	[Press Enter]	Item Help
▶ Super IO Device	[Press Enter]	
▶ Watch Dog Timer Select	[Disabled]	Menu Level ▶
▶ USB Device Setting	[Press Enter]	
↑ ↓ ← → : Move Enter: Select +/-/PU/PD: Value F10:Save Esc: Exit F1:General Help F5:Previous Value F6:Fail-Safe Defaults F7:Optimized Default		

### ▶ On Chip IDE Device

Phoenix-Award BIOS CMOS Setup Utility On Chip IDE Device		
IDE HDD Block Mode	[Enabled]	Item Help
IDE DMA transfer access	[Enabled]	
IDE Primary Master PIO	[Auto]	Menu Level ▶
IDE Primary Slave PIO	[Auto]	If your IDE hard
IDE Primary Master UDMA	[Auto]	drive supports block
IDE Primary Slave UDMA	[Auto]	mode select
On-Chip Secondary PCI IDE	[Enabled]	Enabled for
IDE Secondary Master PIO	[Auto]	automatic
IDE Secondary Slave PIO	[Auto]	detection of the
IDE Secondary Master UDMA	[Auto]	optimal number of
IDE Secondary Slave UDMA	[Auto]	lock read/writes
SATA Mode	[IDE]	per sector the drive
LEGACY Mode Support	[Disabled]	can support
↑ ↓ ← → : Move Enter: Select +/-/PU/PD: Value F10:Save Esc: Exit F1:General Help F5:Previous Value F6:Fail-Safe Defaults F7:Optimized Default		

---

### IDE HDD Block Mode

---

Block mode is also called block transfer, multiple commands, or multiple sectors read / write.

If your IDE hard drive supports block mode (most new drives do), select Enabled for automatic detection of the optimal number of block mode (most new drives do), select Enabled for automatic detection of the optimal number of block read /write per sector where the drive can support.

The choice: Enabled (**default**), Disabled.

### IDE DMA transfer access

---

The choice: Enabled (**default**), Disabled.

### IDE Primary/Secondary, Master/Slave PIO

---

The choice: Auto (**default**), Mode0, Mode1, Mode2, Mode3, Mode4.



Caution: Do not use the wrong setting or you will have drive errors.

PIO means Programmed Input/output.

Rather than have the BIOS issue a series of commands to effect a transfer to or from the disk drive, PIO allows the BIOS to tell the controller what it wants and then let the controller and the CPU perform the complete task by themselves.

Your system supports five modes, 0 (default) to 4, which primarily differ in timing.

When Auto is selected, the BIOS will select the best available mode after checking your drive.

Auto	The BIOS will automatically set the system according to your hard disk drive's timing ( <b>default</b> ).
Mode 0-4	You can select a mode that matches your hard disk drive's timing.

### IDE Primary/Secondary, Master/ Slave UDMA

---

The choice: Disabled, Auto (**default**).

---

## On-Chip Secondary PCI IDE

---

These fields allow you to enable or disable the primary and secondary IDE controller.

Select disabled if you want to add a different hard drive controller.

The choice: Enabled (**default**), Disabled.

## SATA Mode

---

Controls the SATA controller's operating mode.

The choice: IDE (**default**), RAID, AHCI.

## LEGACY Mode Support

---

The choice: Enabled, Disabled (**default**).

## ➤ Super IO Device

---

Phoenix-Award BIOS CMOS Setup Utility		
Super IO Device		
Onboard FDC Controller	[Enabled]	Item Help
Onboard Serial Port 1	[3F8/IRQ4]	
Onboard Serial Port 2	[2F8/IRQ3]	Menu Level ▶
UART Mode Select	[Normal]	
x RxD , TxD Active	Hi, Lo	
x IR Transmission Delay	Enabled	
x UR2 Duplex Mode	Half	
Onboard Parallel Port	[378/IRQ7]	
Parallel Port Mode	[SPP]	
x EPP Mode Select	EPP1.7	
x ECP Mode Use DMA	3	
PWRON After PWR-Fail	[Off]	
↑ ↓ ← → : Move Enter: Select +/-/PU/PD: Value F10:Save Esc: Exit F1:General Help F5:Previous Value F6:Fail-Safe Defaults F7:Optimized Default		

## Onboard FDC Controller

---

The choice: Enabled (**default**), Disabled.

## Onboard Serial Port 1

---

Select an address and corresponding interrupt for the first serial ports.

The choice: Disable, 3F8/IRQ4 (**default**), 2F8/IRQ3, 3E8/IRQ4, 2E8/IRQ3, Auto.

---

## Onboard Serial Port 2

---

Select an address and corresponding interrupt for the second serial ports.

The choice: Disable, 3F8/IRQ4, 2F8/IRQ3 (**default**), 3E8/IRQ4, 2E8/IRQ3, Auto.

## UART Mode Select

---

This item allows you to select which mode for the Onboard Serial Port 2.

The choice: IrDA, ASKIR, Normal (**default**).

If UART Mode Select is [IrDA] and [ASKIR] will show:

Phoenix-Award BIOS CMOS Setup Utility		
Super IO Device		
Onboard FDC Controller	[Enabled]	Item Help  Menu Level ▶
Onboard Serial Port 1	[3F8/IRQ4]	
Onboard Serial Port 2	[2F8/IRQ3]	
UART Mode Select	[IrDA]	
RxD , TxD Active	[Hi, Lo]	
IR Transmission Delay	[Enabled]	
UR2 Duplex Mode	[Half]	
Onboard Parallel Port	[378/IRQ7]	
Parallel Port Mode	[SPP]	
x EPP Mode Select	EPP1.7	
x ECP Mode Use DMA	3	
PWRON After PWR-Fail	[Off]	
↑ ↓ ← → : Move Enter: Select +/-/PU/PD: Value F10:Save Esc: Exit F1:General Help F5:Previous Value F6:Fail-Safe Defaults F7:Optimized Default		

## RxD, TxD Active

---

The choice:

UART Mode Select	
Hi, Hi	.....[ ]
Hi, Lo	.....[ ]
Lo, Hi	.....[ ]
Lo, Lo	.....[ ]
↑↓: Move Enter: Accept ESC: Abort	

---

### IR Transmission Delay

---

The choice: Disabled, Enabled **(default)**.

### UR2 Duplex Mode

---

The choice: Full, Half **(default)**.

### Onboard Parallel Port

---

This item allows you to determine onboard parallel port controller I/O address setting.

The choice: 378/IRQ7 **(default)**, 278/IRQ5, 3BC/IRQ7, Disabled.

### Parallel Port Mode

---

The choice: SPP **(default)**, EPP, ECP, ECP+EPP, Normal.

SPP	Sets the parallel port to function as a Standard Parallel Port. This is the default (and slowest) option.
EPP	Sets the parallel port to Enhanced Parallel Port mode. Sometimes also called "Bi-directional"
ECP	Sets the parallel port up as an Enhanced Capabilities Port. This setting requires the use of a DMA channel

If Parallel Port Mode Select is **[SPP]** and **[Normal]** will show:

Phoenix-Award BIOS CMOS Setup Utility		
Super IO Device		
Onboard Serial Port 1	<b>[3F8/IRQ4]</b>	Item Help
Onboard Serial Port 2	<b>[2F8/IRQ3]</b>	
UART Mode Select	<b>[IrDA]</b>	Menu Level ►
x RxD , TxD Active	Hi, Lo	
x IR Transmission Delay	Enabled	
x UR2 Duplex Mode	Half	
Onboard Parallel Port	<b>[378/IRQ7]</b>	
Parallel Port Mode	<b>[SPP]</b>	
x EPP Mode Select	EPP1.7	
x ECP Mode Use DMA	3	
PWRON After PWR-Fail	<b>[Off]</b>	
↑ ↓ ← → : Move Enter: Select +/-/PU/PD: Value F10:Save Esc: Exit F1:General Help F5:Previous Value F6:Fail-Safe Defaults F7:Optimized Default		

If Parallel Port Mode Select is **[EPP]** will show:

Phoenix-Award BIOS CMOS Setup Utility		
Super IO Device		
Onboard Serial Port 1	[3F8/IRQ4]	Item Help  Menu Level ►
Onboard Serial Port 2	[2F8/IRQ3]	
UART Mode Select	[IrDA]	
RxD , TxD Active	[Hi, Lo]	
IR Transmission Delay	[Enabled]	
UR2 Duplex Mode	[Half]	
Onboard Parallel Port	[378/IRQ7]	
Parallel Port Mode	<b>[EPP]</b>	
<b>EPP Mode Select</b>	<b>[1.7]</b>	
x ECP Mode Use DMA	3	
PWRON After PWR-Fail	[Off]	
↑ ↓ ← → : Move Enter: Select +/-/PU/PD: Value F10:Save Esc: Exit F1:General Help F5:Previous Value F6:Fail-Safe Defaults F7:Optimized Default		

### EPP Mode Select

Select EPP port type 1.7 or 1.9.

The choice: 1.7 (**default**), 1.9.

If Parallel Port Mode Select is **[ECP]** will show:

Phoenix-Award BIOS CMOS Setup Utility		
Super IO Device		
Onboard Serial Port 1	[3F8/IRQ4]	Item Help  Menu Level ►
Onboard Serial Port 2	[2F8/IRQ3]	
UART Mode Select	[IrDA]	
RxD , TxD Active	[Hi, Lo]	
IR Transmission Delay	[Enabled]	
UR2 Duplex Mode	[Half]	
Onboard Parallel Port	[378/IRQ7]	
Parallel Port Mode	<b>[ECP]</b>	
x EPP Mode Select	1.7	
<b>ECP Mode Use DMA</b>	<b>[3]</b>	
PWRON After PWR-Fail	[Off]	
↑ ↓ ← → : Move Enter: Select +/-/PU/PD: Value F10:Save Esc: Exit F1:General Help F5:Previous Value F6:Fail-Safe Defaults F7:Optimized Default		

---

## ECP Mode Use DMA

---

If your system supports ECP parallel port mode and you have the port set to use ECP, you must use this setting to assign a DMA channel for use by the port.

The choice: DMA1, DMA3 (**default**).

If Parallel Port Mode Select is [ECP+EPP] will show:

Phoenix-Award BIOS CMOS Setup Utility		
Super IO Device		
Onboard Serial Port 1	[3F8/IRQ4]	Item Help Menu Level ▶
Onboard Serial Port 2	[2F8/IRQ3]	
UART Mode Select	[IrDA]	
RxD , TxD Active	[Hi, Lo]	
IR Transmission Delay	[Enabled]	
UR2 Duplex Mode	[Half]	
Onboard Parallel Port	[378/IRQ7]	
Parallel Port Mode	[ECP+EPP]	
EPP Mode Select	[1.7]	
ECP Mode Use DMA	[3]	
PWRON After PWR-Fail	[Off]	
↑ ↓ ← → : Move Enter: Select +/-/PU/PD: Value F10:Save Esc: Exit F1:General Help F5:Previous Value F6:Fail-Safe Defaults F7:Optimized Default		

---

## EPP Mode Select

---

Select EPP port type 1.7 or 1.9.

The choice: 1.7 (**default**), 1.9.

---

## ECP Mode Use DMA

---

If your system supports ECP parallel port mode and you have the port set to use ECP, you must use this setting to assign a DMA channel for use by the port.

The choice: DMA1, DMA3 (**default**).

---

## PWRON After PWR-Fail

---

When power fails, you can select power ON or Off or Former status.

The choice: Off (**default**), On, Former-Sts.

---

## Watch Dog Timer Select

---

The choice: Disabled (**default**), Enable.

### ➤ USB Device Setting

---

Phoenix-Award BIOS CMOS Setup Utility		
USB Device Setting		
USB 1.0 Controller	[Enabled]	Item
USB 2.0 Controller	[Enabled]	Help
USB Operation Mode	[High Speed]	
USB Keyboard Function	[Enabled]	Menu
USB Mouse Function	[Enabled]	Level
USB Storage Function	[Enabled]	▶
***USB Mass Storage Device Boot Setting***		
↑ ↓ ← → : Move Enter: Select +/-/PU/PD: Value F10:Save Esc: Exit F1:General Help F5:Previous Value F6:Fail-Safe Defaults F7:Optimized Default		

#### USB 1.0 Controller

---

This entry is for disable/enable USB1.0 controller only. The BIOS itself may/may not have high speed USB support.

If the BIOS has high speed USB support built in, the support will be automatically turn on when high speed device were attached.

The choice: Enabled (**default**), Disabled.

#### USB 2.0 Controller

---

This entry is for disable/enable USB2.0 controller only. The BIOS itself may/may not have high speed USB support.

If the BIOS has high speed USB support built in, the support will be automatically turn on when high speed device were attached.

The choice: Enabled (**default**), Disabled.

#### USB Operation Mode

---

The choice: Full/Low Speed, High Speed (**default**).

#### USB Keyboard Function

---

The choice: Enabled (**default**), Disabled.

---

### USB Mouse Function

The choice: Enabled (**default**), Disabled.

### USB Storage Function

The choice: Enabled (**default**), Disabled.

## 4.6 Power Management Setup

The Power Management Setup allows you to configure your system to most effectively save energy while operating in a manner consistent with your own style of computer use.

Phoenix-Award BIOS CMOS Setup Utility		Item Help
Power Management Setup		Menu Level ▶
▶ PCI Express PM Function	[Press Enter]	
ACPI Function	[Enabled]	
Power Management	[User Define]	
Video Off Method	[DPMS]	
Video Off In Suspend	[Yes]	
Suspend Type	[Stop Grant]	
MODEM Use IRQ	[3]	
Suspend Mode	[Disabled]	
HDD Power Down	[Disabled]	
Soft-Off by PWR-BTTN	[Instant-Off]	
CPU THRM-Throttling	[50.0%]	
Wake-Up by PCI card	[Enabled]	
Power On by Ring	[Enabled]	
USB KB Wake-Up From S3	[Disabled]	
Resume by Alarm	[Disabled]	
x Data(of Month)Alarm	0	
x Time(hh: mm: ss)Alarm	0 : 0 : 0	
**Reload Global TimerEvents**		
Primary IDE 0	[Disabled]	
Primary IDE 1	[Disabled]	
Secondary IDE 0	[Disabled]	
Secondary IDE 1	[Disabled]	
FDD , COM , LPT Port	[Disabled]	
PCI PIRQ[A-D]#	[Disabled]	
↑ ↓ ← → : Move Enter: Select +/-/PU/PD: Value F10:Save Esc: Exit F1:General Help F5:Previous Value F6:Fail-Safe Defaults F7:Optimized Default		

---

## ➤ PCI Express PM Funtion

---

Phoenix-Award BIOS CMOS Setup Utility	
PCI Express PM Funtion	
PCI Express PME <b>[Enabled]</b>	Item Help
	Menu Level ▶
↑ ↓ ← → : Move   Enter: Select   +/-/PU/PD: Value   F10:Save Esc: Exit   F1:General Help F5:Previous Value F6:Fail-Safe Defaults F7:Optimized Default	

The choice: Enabled (**default**), Disabled.

---

## ACPI Function

This item allows you to enable/disable the Advanced Configuration and Power Management (ACPI).

The choice: Enabled (**default**), Disabled.

---

## Power Management

The choice: User Define (**default**), Min Saving, Max Saving.

Max Saving	Maximum power savings. Only Available for SL CPUs. Inactivity period is 1 minute in each mode.
User Define	Set each mode individually. Select time-out periods in the section for each mode, below.
Min Saving	Minimum power savings. Inactivity period is 1 hour in each mode (except the hard drive).

---

## Video off Method

---

This determines the manner in which the monitor is blanked.  
This specifies the power saving state that the VGA video subsystem enters after the specified period of display inactivity has expired.  
The choice: Blank Screen, V/H SYNC+ Blank, DPMS (**default**).

Blank Screen	The BIOS will only black the screen when the system gets into power management mode and writes blanks to the video buffer.
V/H SYNC + Blank	Writes blanks to the video buffer, and turns off the vertical and horizontal scanning.
DPMS	Allows the BIOS to control the video display card if it supports the DPMS feature ( <b>default</b> ).

---

## Video Off In Suspend

---

This field is used to activate the video off feature when the system enters the Suspend mode.  
The choice: No, Yes (**default**).

---

## Suspend Type

---

The choice: Stop Grant (**default**),PwrOn Suspend.

---

## MODEM Use IRQ

---

This field is used to set an IRQ channel for the modem installed in your system.  
The choice: NA, 3 (**default**), 4, 5, 7, 9, 10, 11.

---

## Suspend Mode

---

This field specifies the length of time of system inactivity while in full power on state before the computer enters suspend mode and motivates the enable 'Wake up Events in Doze & Standby' / 'PM Events'.  
The choice: 1Min, 2Min, 4Min, 8Min, 12Min, 20Min, 30Min, 40Min,1Hour, Disable (**default**).

---

## HDD Power Down

---

When enable and after the set time of system inactivity, the hard disk drive will be powered down while all other devices remain active.

The choice: 1Min, 2Min, 3Min, 4Min, 5Min, 6Min, 7Min, 8Min, 9Min, 10Min, 11Min, 12Min, 13Min, 14Min, 15Min, Disable **(default)**.

## Soft-Off by PWR-BTTN

---

This field defines the power off mode when using an ATX power supply.

The choice: Instant-Off, Delay 4 Sec.

Instant-Off	Press power button then Power off instantly <b>.(default)</b>
Delay 4 Sec	Press power button 4 sec. to Power off. Enter suspend if button is pressed less than 4 sec.

## CPU THRM-Throttling

---

This field allows you to select the CPU THRM-Throttling rate.

The choice: 75.0%, 50.0% **(default)**, 25.0%.

## Wake-Up by PCI card

---

Enable/Disable PCI PME wake up function.

The choice: Enabled **(default)**, Disabled.

## Power On by Ring

---

Enable/Disable Power on by Ring function.

The choice: Enabled **(default)**, Disabled.

## USB KB Wake-Up From S3

---

This field, when enabled, allows you to use a USB keyboard to wake up a system that is in the S3 (STR - Suspend To RAM) state. This can be configured only if the 'ACPI Suspend Type' field is set to 'S3 (STR)'.

The choice: Enabled, Disabled **(default)**.

---

## Resume by Alarm

---

You can set "Resume by Alarm" item to enabled and key in Date/time to power on system.  
The choice: Enabled, Disabled (**default**).

If Resume by Alarm is [**Enabled**], can choice Date Alarm and Time Alarm:

### Date (of Month) Alarm

---

Every day, 1~31.

Date(of Moth)Alarm
Min= 0 Max= 31
Key in a DEC number: <input type="text"/>
↑↓: Move Enter: Accept ESC:Abort

### Time (hh: mm: ss) Alarm

---

(0~23): (0~59): (0~59).

Time (hh: mm: ss) Alarm
Min= 0 Max= 23
Key in a DEC number: <input type="text"/>
↑↓: Move Enter: Accept ESC:Abort

### Primary/ Secondary IDE 0/1

---

When Enabled, the system will resume from suspend mode if Primary IDE 0 (1) or Secondary IDE 0 (1) is active.  
The choice: Enabled, Disabled (**default**).

---

## **FDD, COM, LPT Port**

---

When Enabled, the system will resume from suspend mode if FDD, COM port, or LPT port is active.

The choice: Enabled, Disabled (**default**).

## **PCI PIRQ [A-D] #**

---

When Enabled, the system will resume from suspend mode if interrupt occurs.

The choice: Enabled, Disabled (**default**).

## 4.7 PnP/PCI Configuration

This section describes configuring the PCI bus system. PCI, or Personal Computer Interconnect, is a system which allows I/O devices to operate at speeds nearing the speed the CPU itself uses when communicating with its own special components.

This section covers some very technical items and it is strongly recommended that only experienced users should make any changes to the default settings.

Phoenix-Award BIOS CMOS Setup Utility PnP/PCI Configuration		
Init Display First	[PCI Slot]	Item Help
Reset Configuration Data	[Disabled]	
Resources Controlled By	[Auto(ESCD)]	Menu Level ►
x IRQ Resources	Press Enter	
x DMA Resources	Press Enter	
PCI/VGA Palette Snoop	[Disabled]	
INT Pin 1 Assignment	[Auto]	
INT Pin 2 Assignment	[Auto]	
INT Pin 3 Assignment	[Auto]	
INT Pin 4 Assignment	[Auto]	
INT Pin 5 Assignment	[Auto]	
INT Pin 6 Assignment	[Auto]	
INT Pin 7 Assignment	[Auto]	
INT Pin 8 Assignment	[Auto]	
**PCI Express relative items**		
Maximum Payload Size	[128]	
↑ ↓ ← → : Move    Enter: Select    +/-/PU/PD: Value    F10:Save    Esc: Exit    F1:General Help F5:Previous Value    F6:Fail-Safe Defaults    F7:Optimized Default		

### Init Display First

This item allows you to choose which one to activate first, PCI Slot or onchip VGA.

The choice: PCI Slot (**default**), Onboard, PCIEx.

---

## Reset Configuration Data

---

Default is disabled. Select Enabled to reset Extended System Configuration Data (ESCD) when you exit Setup if you have installed a new add-on and the system reconfiguration has caused such a serious conflict that the OS cannot boot.  
The choice: Enabled, Disabled (**default**).

## Resources Controlled By

---

BIOS can automatically configure all the boot and Plug and Play compatible devices. If you choose Auto, you cannot select IRQ DMA and memory base address fields, since BIOS automatically assigns them.  
The choice: Auto (ESCD) (**default**), Manual.

If Resources Controlled by is **[Manual]**, can choice IRQ Resource:

Phoenix-Award BIOS CMOS Setup Utility		
PnP/PCI Configuration		
Init Display First	[PCI Slot]	Item Help
Reset Configuration Data	[Disabled]	Menu Level ►
Resources Controlled By	[Manual]	
► IRQ Resources	[Press Enter]	
► DMA Resources	[Press Enter]	
PCI/VGA Palette Snoop	[Disabled]	
INT Pin 1 Assignment	[Auto]	
INT Pin 2 Assignment	[Auto]	
INT Pin 3 Assignment	[Auto]	
INT Pin 4 Assignment	[Auto]	
INT Pin 5 Assignment	[Auto]	
INT Pin 6 Assignment	[Auto]	
INT Pin 7 Assignment	[Auto]	
INT Pin 8 Assignment	[Auto]	
**PCI Express relative items**		
Maximum Payload Size	[128]	
↑ ↓ ← → : Move Enter: Select +/-/PU/PD: Value F10:Save Esc: Exit F1:General Help F5:Previous Value F6:Fail-Safe Defaults F7:Optimized Default		

## ➤ IRQ Resource

When resources are controlled manually, assign each system interrupt a type, depending on the type of device using the interrupt. This item allows you to determine the IRQ assigned to the ISA bus and is not available to any PCI slot.

Phoenix-Award BIOS CMOS Setup Utility		
IRQ Resource		
IRQ-3 assigned to	[PCI /ISA PnP]	Item Help  Menu Level ▶ Legacy ISA for devices compliant with the original PC AT bus specification, PCI/ISA PnP for devices compliant with the Plug and Play standard whether designed for PCI or ISA bus architecture
IRQ-4 assigned to	[PCI /ISA PnP]	
IRQ-5 assigned to	[PCI /ISA PnP]	
IRQ-7 assigned to	[PCI /ISA PnP]	
IRQ-9 assigned to	[PCI /ISA PnP]	
IRQ-10 assigned to	[PCI /ISA PnP]	
IRQ-11 assigned to	[PCI /ISA PnP]	
IRQ-12 assigned to	[PCI /ISA PnP]	
IRQ-14 assigned to	[PCI /ISA PnP]	
IRQ-15 assigned to	[PCI /ISA PnP]	
↑ ↓ ← → : Move   Enter: Select   +/-/PU/PD: Value   F10:Save   Esc: Exit   F1:General Help F5:Previous Value   F6:Fail-Safe Defaults   F7:Optimized Default		

### IRQ-3,4,5,7,9,10,11,12,14,15 assigned to

IRQ-3 assigned to	
PCI /ISA PnP	..... [ <input checked="" type="checkbox"/> ]
Legacy ISA	..... [ <input type="checkbox"/> ]
↑↓: Move Enter: Accept ESC:Abort	

The choice: PCI/ISA PnP, Legacy ISA.

---

## ➤DMA Resource

---

When resources are controlled manually, assign each system interrupt a type, depending on the type of device using the interrupt. This item allows you to determine the IRQ assigned to the ISA bus and is not available to any PCI slot.

Phoenix-Award BIOS CMOS Setup Utility		
DMA Resource		
DMA-0 assigned to	[PCI /ISA PnP]	Item Help  Menu Level ► Legacy ISA for devices compliant with the original PC AT bus specification, PCI/ISA PnP for devices compliant with the Plug and Play standard whether designed for PCI or ISA bus architecture
DMA-1 assigned to	[PCI /ISA PnP]	
DMA-3 assigned to	[PCI /ISA PnP]	
DMA-5 assigned to	[PCI /ISA PnP]	
DMA-6 assigned to	[PCI /ISA PnP]	
DMA-7 assigned to	[PCI /ISA PnP]	
↑ ↓ ← → : Move Enter: Select +/-/PU/PD: Value F10:Save Esc: Exit F1:General Help F5:Previous Value F6:Fail-Safe Defaults F7:Optimized Default		

### DMA-0 , 1, 3, 5, 6, 7 assigned to

---

IRQ-3 assigned to	
PCI /ISA PnP	..... [ <input checked="" type="checkbox"/> ]
Legacy ISA	..... [ <input type="checkbox"/> ]
↑↓: Move Enter: Accept ESC:Abort	

The choice: PCI/ISA PnP, Legacy ISA.

---

## **PCI/VGA Palette Snoop**

---

This BIOS feature determines if your graphics card should allow VGA palette snooping by a fixed function display card.

The choice: Enabled, Disabled **(default)**.

## **INT Pin 1/2/3/4/5/6/7/8 Assignment**

---

The choice: Auto **(default)**, 3, 4, 5, 7, 9, 10, 11, 12, 14, 15.

## **Maximum Payload Size**

---

The choice: 128 **(default)**.

---

## 4.8 PC Health Status

This section helps you to get more information about your system including CPU temperature, FAN speed and voltages.

It is recommended that you contact with your motherboard supplier to get proper value about your setting of the CPU temperature.

Phoenix-Award BIOS CMOS Setup Utility		
PC Health Status		
CPU Warning Temperature	[Disabled]	Item Help
Current System Temp.	69°C / 156°F	
Current CPU Temp.	37°C / 98°F	Menu Level ►
CPU FAN Speed	0 RPM	
CHASSIS Fan Speed	3443 RPM	
POWER Fan Speed	0 RPM	
Vcore	1.26V	
+1.5V	1.53V	
+3.3V	3.39V	
+5V	5.16V	
+12V	12.34V	
-12V	-64.98V	
-5V	-62.03V	
VBAT(V)	3.32V	
5VSB(V)	4.89V	
Shutdown Temperature	[Disabled]	
↑ ↓ ← → : Move Enter: Select +/-/PU/PD: Value F10:Save Esc: Exit F1:General Help F5:Previous Value F6:Fail-Safe Defaults F7:Optimized Default		

---

### CPU Warning Temperature

Select the CPU over-heated warning temperature.

The choice: Disabled (**default**), 50°C/122°F, 53°C/127°F, 56°C/133°F, 60°C/140°F, 63°C/145°F, 66°C/151°F, and 70°C/158°F.

---

### Current System Temp

Show System Temperature.

---

### Current CPU Temp

Shows Board Temperature.

---

### **CPU FAN Speed**

---

Shows CPU Fan speed.

### **CHASSIS Fan Speed**

---

Shows CHASSIS Fan speed.

### **POWER Fan Speed**

---

Shows POWER Fan speed.

### **Shutdown Temperature**

---

Select the CPU over-heated shutdown temperature.

The choice: Disabled (**default**), 60°C/140°F, 65°C/149°F, 70°C/158°F, 75°C/167°F.

---

## 4.9 Load Fail-Safe Defaults

When you press <Enter> on this item you get a confirmation dialog box with a message similar to:

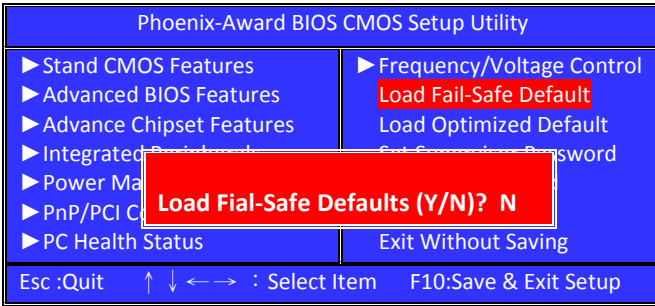

Pressing '**Y**' loads the BIOS default values for the most stable, minimal-performance system operations.

## 4.10 Load Optimized Defaults

When you press <Enter> on this item you get a confirmation dialog box with a message similar to:

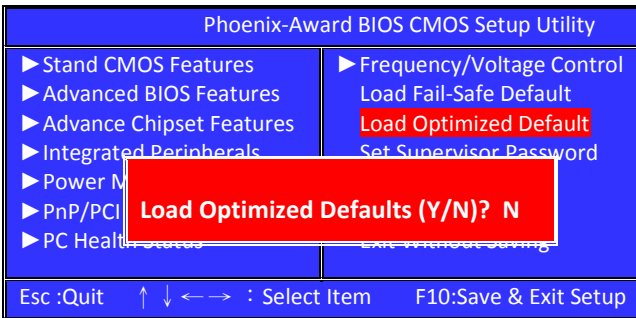

Pressing '**Y**' loads the default values that are factory settings for optimal performance system operations.

---

## 4.11 Set Supervisor/ User Password

You can set either supervisor or user password, or both of them.

The differences between are:

**Supervisor password:** can enter and change the options of the setup menus.

**User password:** just can only enter but do not have the right to change the options of the setup menus.

When you select this function, the following message will appear at the center of the screen to assist you in creating a password.

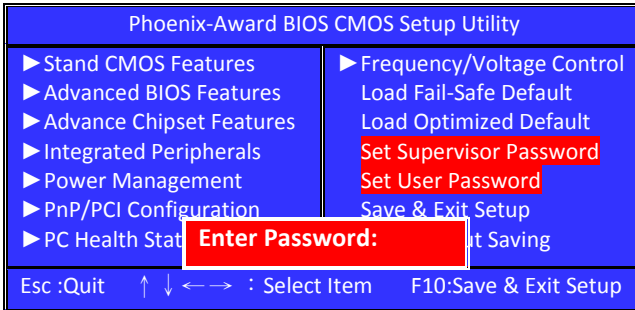

---

### ENTER PASSWORD:

Type the password, up to eight characters in length, and press <Enter>.

The password typed now will clear any previously entered password from CMOS memory.

You will be asked to confirm the password.

Type the password again and press <Enter>.

You may also press <Esc> to abort the selection and not enter a password.

To disable a password, just press <Enter> when you are prompted to enter the password.

A message will confirm the password will be disabled.

Once the password is disabled, the system will boot and you can enter Setup freely.

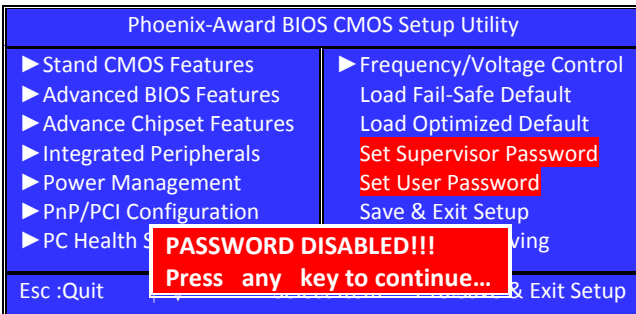

### PASSWORD DISABLED:

When a password has been enabled, you will be prompted to enter it every time you try to enter Setup. This prevents an unauthorized person from changing any part of your system configuration.

Additionally, when a password is enabled, you can also require the BIOS to request a password every time your system is rebooted. This would prevent unauthorized use of your computer.

You determine when the password is required within the BIOS Features Setup Menu and its Security option. If the Security option is set to "System", the password will be required both at boot and at entry to Setup. If set to "Setup", prompting only occurs when trying to enter Setup.

---

## 4.12 Save & Exit Setup

Pressing <Enter> on this item asks for confirmation:

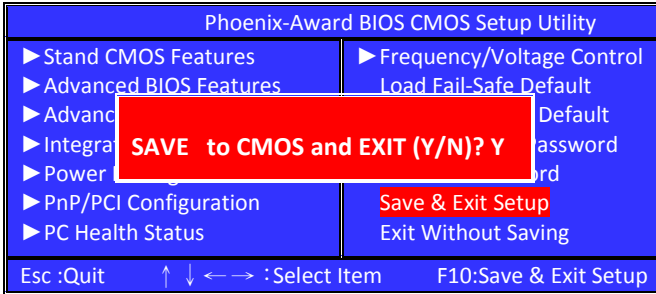

Pressing “Y” stores the selections made in the menus in CMOS – a special section of memory that stays on after you turn your system off. The next time you boot your computer, the BIOS configures your system according to the Setup selections stored in CMOS. After saving the values the system is restarted again.

## 4.13 Exit Without Saving

Pressing <Enter> on this item asks for confirmation:

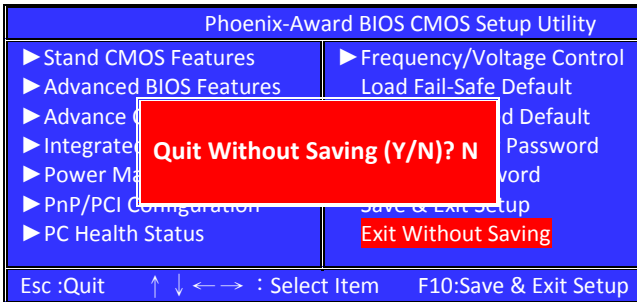

This allows you to exit Setup without storing in CMOS any change. The previous selections remain in effect. This exits the Setup utility and restarts your computer.

# 5

---

## Appendix

This chapter provides the appendices of the user manual. The topics covered are as follows:

I/O Port Address Map .....	90
Interrupt Request Lines (IRQ) .....	91
Post Beep .....	92
TR-6001 Mechanical Drawings .....	93-99
TR-6001 PCI 6S Drawing .....	100
TR-6001 1U USB Filler Drawing .....	101

---

## A. I/O Port Address Map

Each peripheral device in the system is assigned a set of I/O port addresses which also becomes the identity of the device.

There is a total of 1K port address space available.

The following table lists the I/O port addresses used on the Industrial CPU Card.

Address	Device Description
000h - 01Fh	DMA Controller #1
020h - 03Fh	Interrupt Controller #1
040h - 05Fh	Timer
060h - 06Fh	Keyboard Controller
070h - 07Fh	Real Time Clock, NMI
080h - 09Fh	DMA Page Register
0A0h - 0BFh	Interrupt Controller #2
0C0h - 0DFh	DMA Controller #2
0F0h	Clear Math Coprocessor Busy Signal
0F1h	Reset Math Coprocessor
1F0h - 1F7h	IDE Interface
278 - 27F	Parallel Port #2(LPT2)
2F8h - 2FFh	Serial Port #2(COM2)
2B0 - 2DF	Graphics adapter Controller
378h - 3FFh	Parallel Port #1(LPT1)
360 - 36F	Network Ports
3B0 - 3BF	Monochrome & Printer adapter
3C0 - 3CF	EGA adapter
3D0 - 3DF	CGA adapter
3F0h - 3F7h	Floppy Disk Controller
3F8h - 3FFh	Serial Port #1(COM1)

---

## ***B. Interrupt Request Lines (IRQ)***

There are a total of 15 IRQ lines available on the Industrial CPU Card. Peripheral devices use interrupt request lines to notify CPU for the service required.

The following table shows the IRQ used by the devices on the Industrial CPU Card.

<b>Level</b>	<b>Function</b>
IRQ0	System Timer Output
IRQ1	Keyboard
IRQ2	Interrupt Cascade
IRQ3	Serial Port #2
IRQ4	Serial Port #1
IRQ5	Reserved
IRQ6	Floppy Disk Controller
IRQ7	Parallel Port #1
IRQ8	Real Time Clock
IRQ9	Software Redirected to Int0Ah
IRQ10	Reserved
IRQ11	Reserved
IRQ12	PS/2 Mouse
IRQ13	80287
IRQ14	Primary IDE
IRQ15	Secondary IDE

---

## ***C. POST Beep***

Currently there are two kinds of beep codes in BIOS.

This code indicates that a **video error** has occurred and the BIOS cannot initialize the video screen to display any additional information.

This beep code consists of a single long beep followed by two short beeps.

The other code indicates that your **DRAM error** has occurred.

This beep code consists of a single long beep repeatedly.

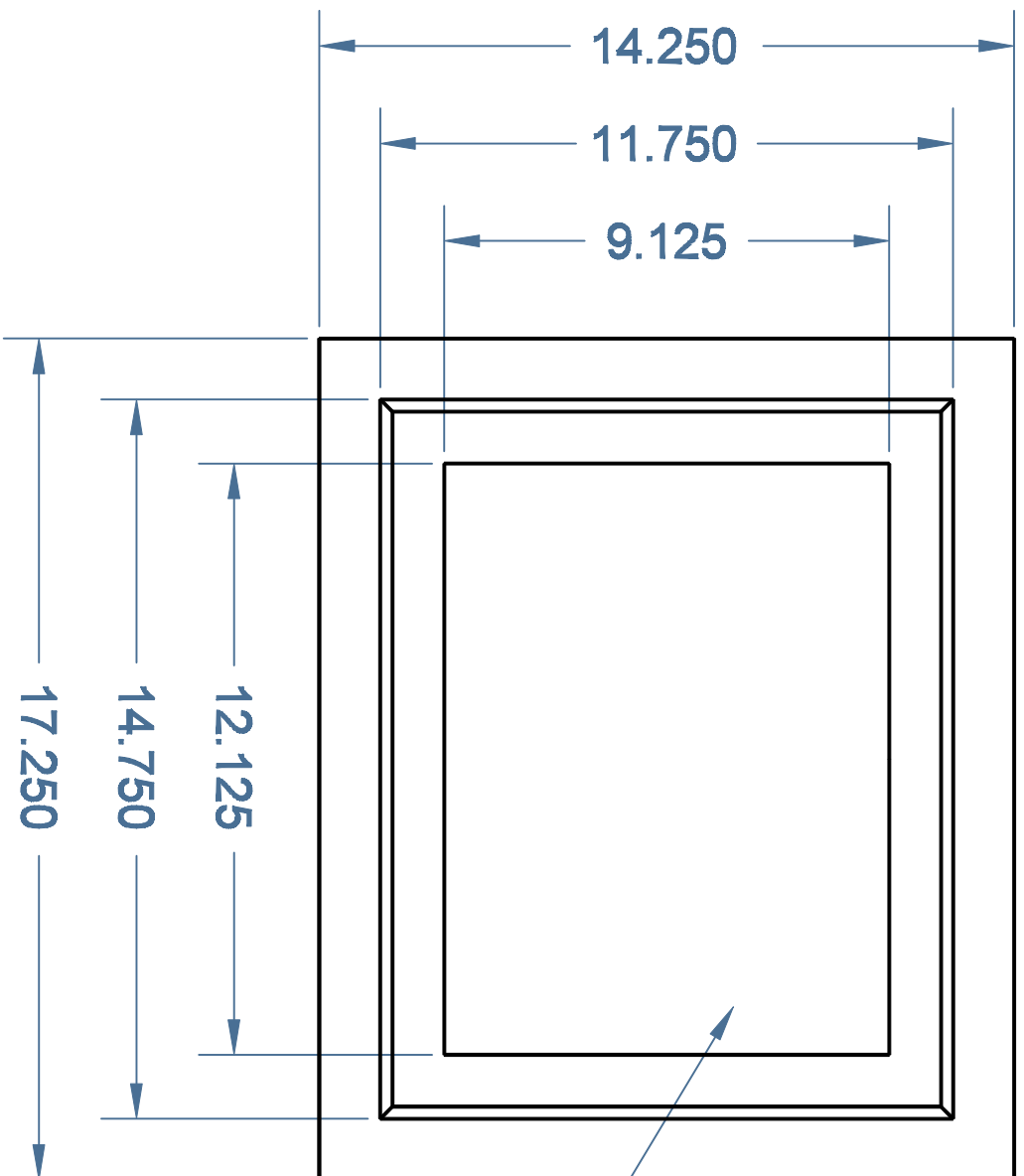

15" LCD MONITOR

**FRONT VIEW**

DATE	06-22-2009	DRAWN BY	B.G.	MODEL	TR-6001
PRODUCT	PANEL PC		REVISION		
FINISH	CRINKLE BLACK POWDER PAINT	TRANSDUCTION	CHECKED BY	NTS	
TITLE	LAYOUT			DRAWING No.	B-420
SCALE					

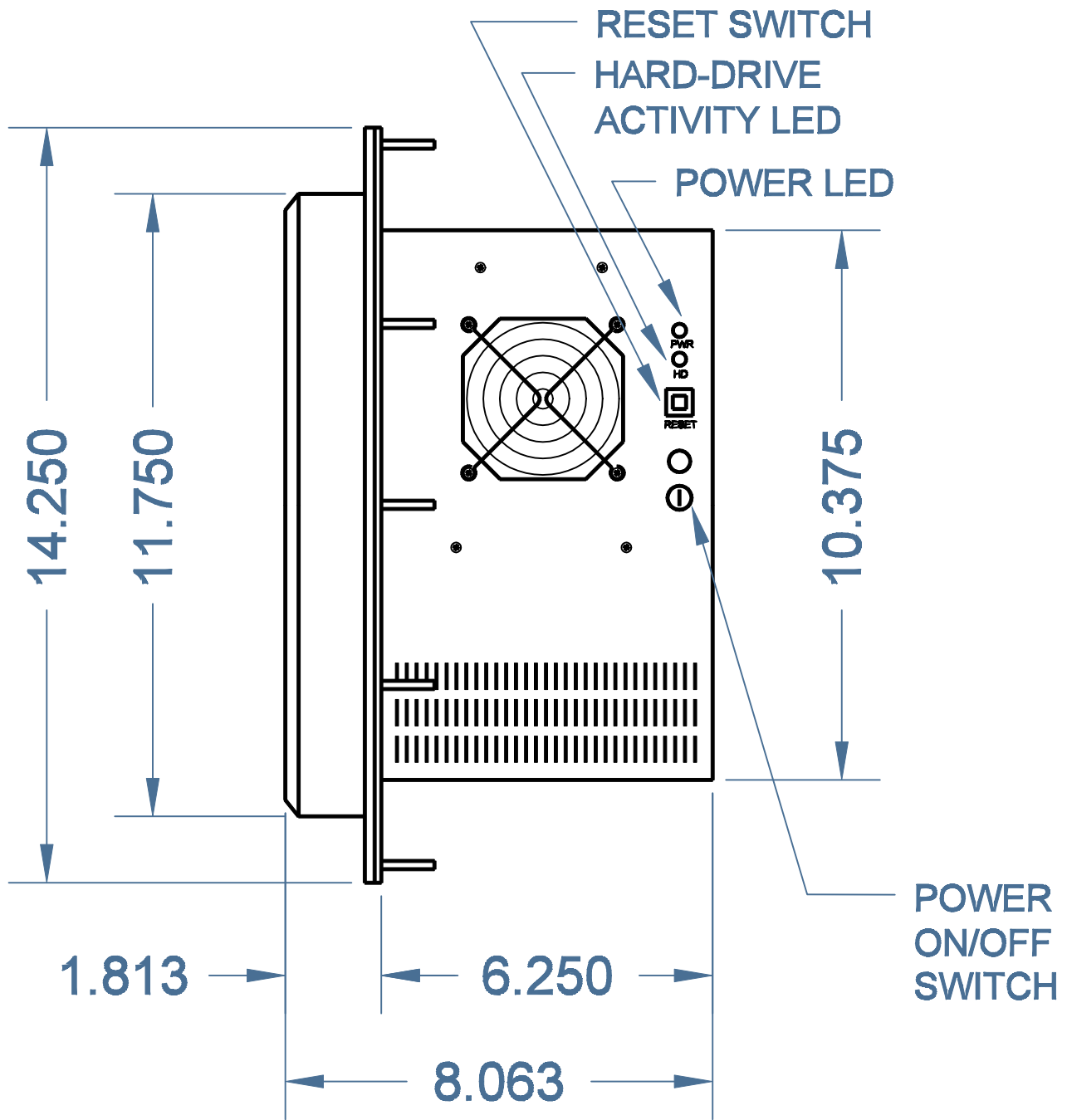

RIGHT SIDE VIEW

DATE <b>06-22-2009</b>	DRAWN BY <b>B. G.</b>	MODEL <b>TR-6001</b>	
PRODUCT <b>PANEL PC</b>		REVISION	SCALE
FINISH <b>CRINKLE BLACK POWDER PAINT</b>	Transduction		CHECKED BY <b>NTS</b>
TITLE <b>LAYOUT</b>		DRAWING No <b>B-421</b>	

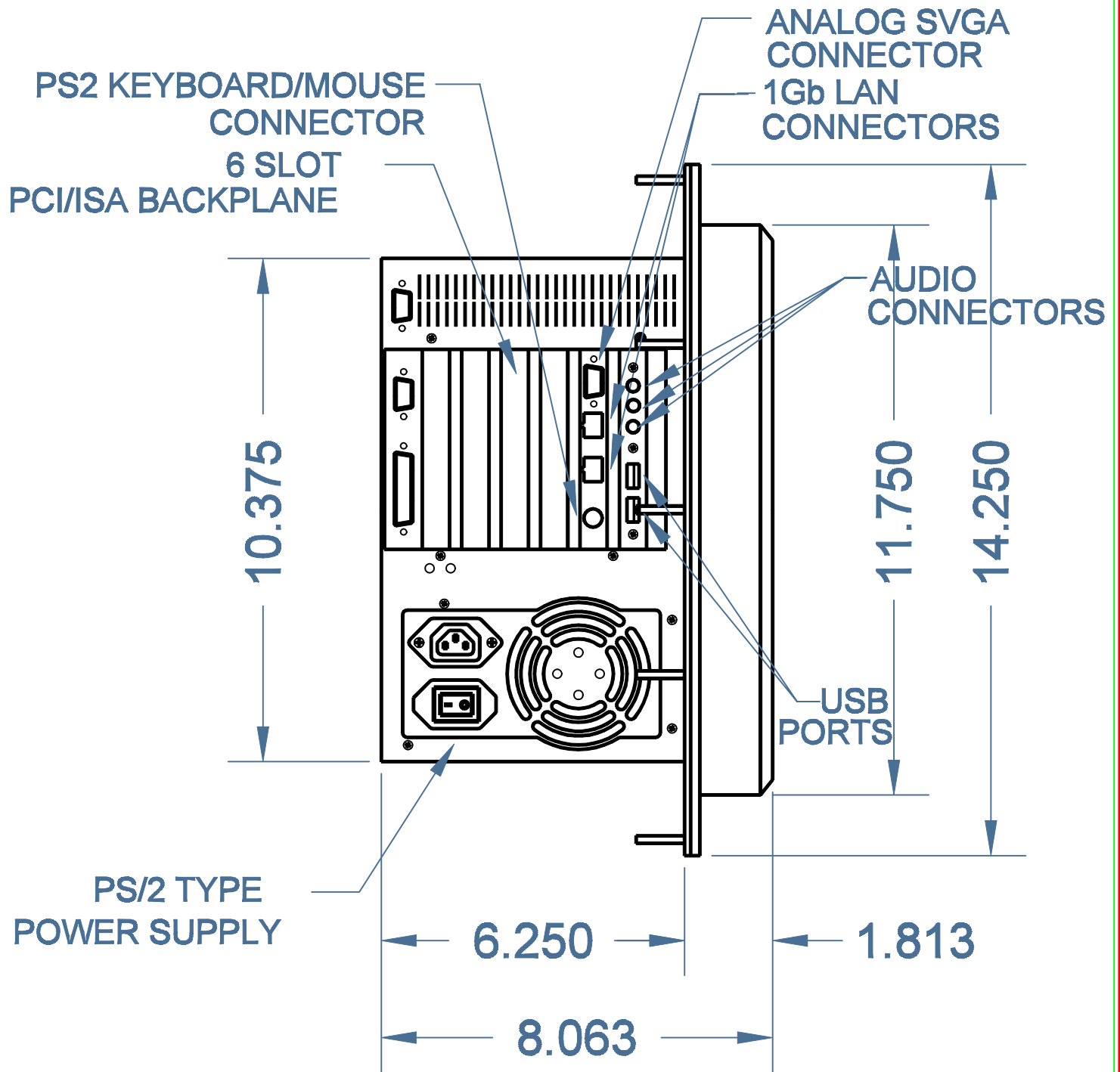

**LEFT SIDE VIEW**

DATE <b>06-22-2009</b>	DRAWN BY <b>B. G.</b>	MODEL <b>TR-6001</b>		
PRODUCT <b>PANEL PC</b>			REVISION	SCALE
FINISH <b>CRINKLE BLACK POWDER PAINT</b>		<b>Transduction</b>	CHECKED BY	<b>NTS</b>
TITLE <b>LAYOUT</b>			DRAWING No <b>B-422</b>	

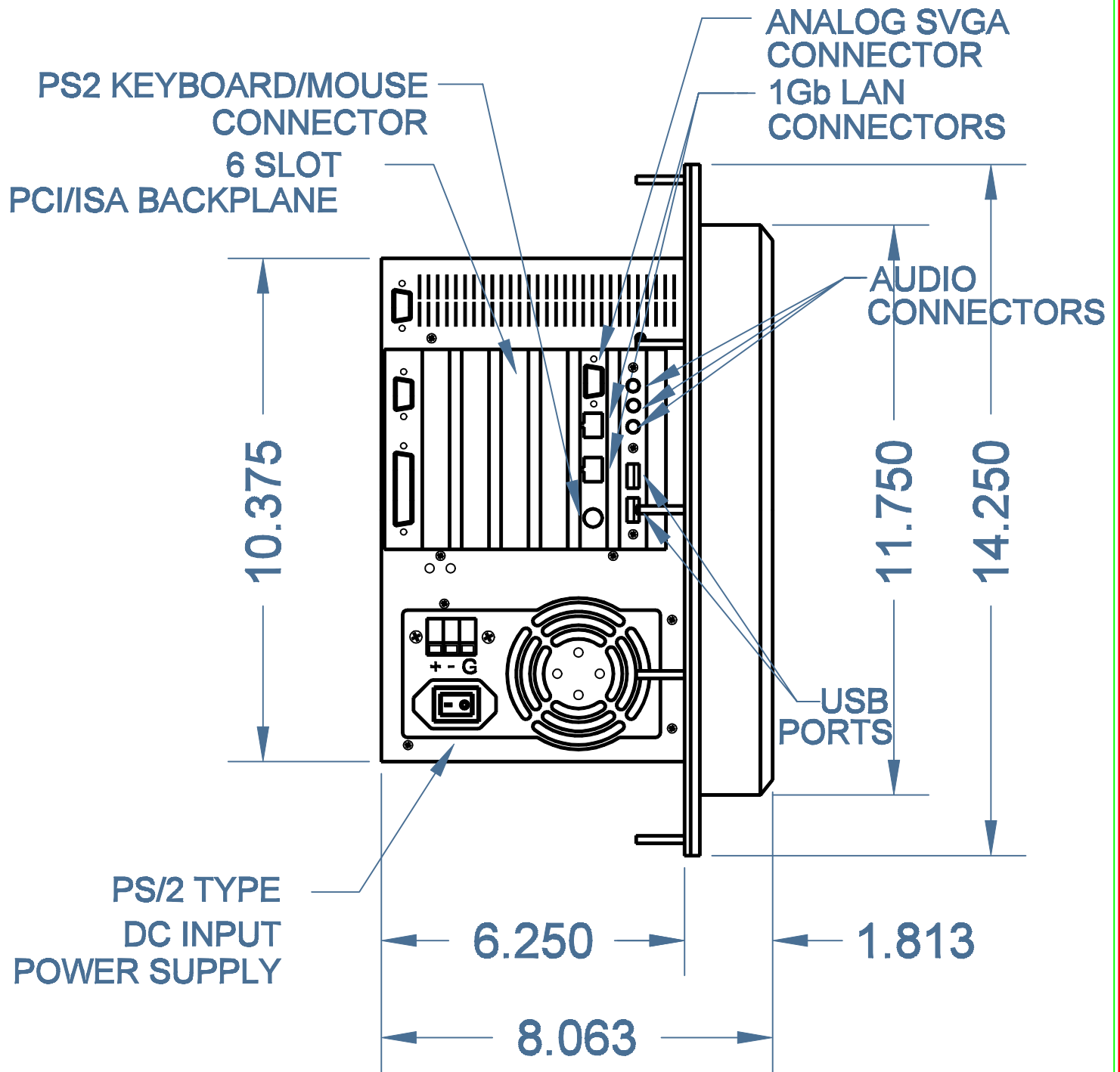

**LEFT SIDE VIEW**

DATE <b>06-22-2009</b>	DRAWN BY <b>B. G.</b>	MODEL <b>TR-6001</b>
PRODUCT <b>PANEL PC</b>		REVISION <b>SCALE</b>
FINISH <b>CRINKLE BLACK POWDER PAINT</b>	<b>Transduction</b>	CHECKED BY <b>NTS</b>
TITLE <b>LAYOUT</b>		DRAWING No <b>B-422A</b>

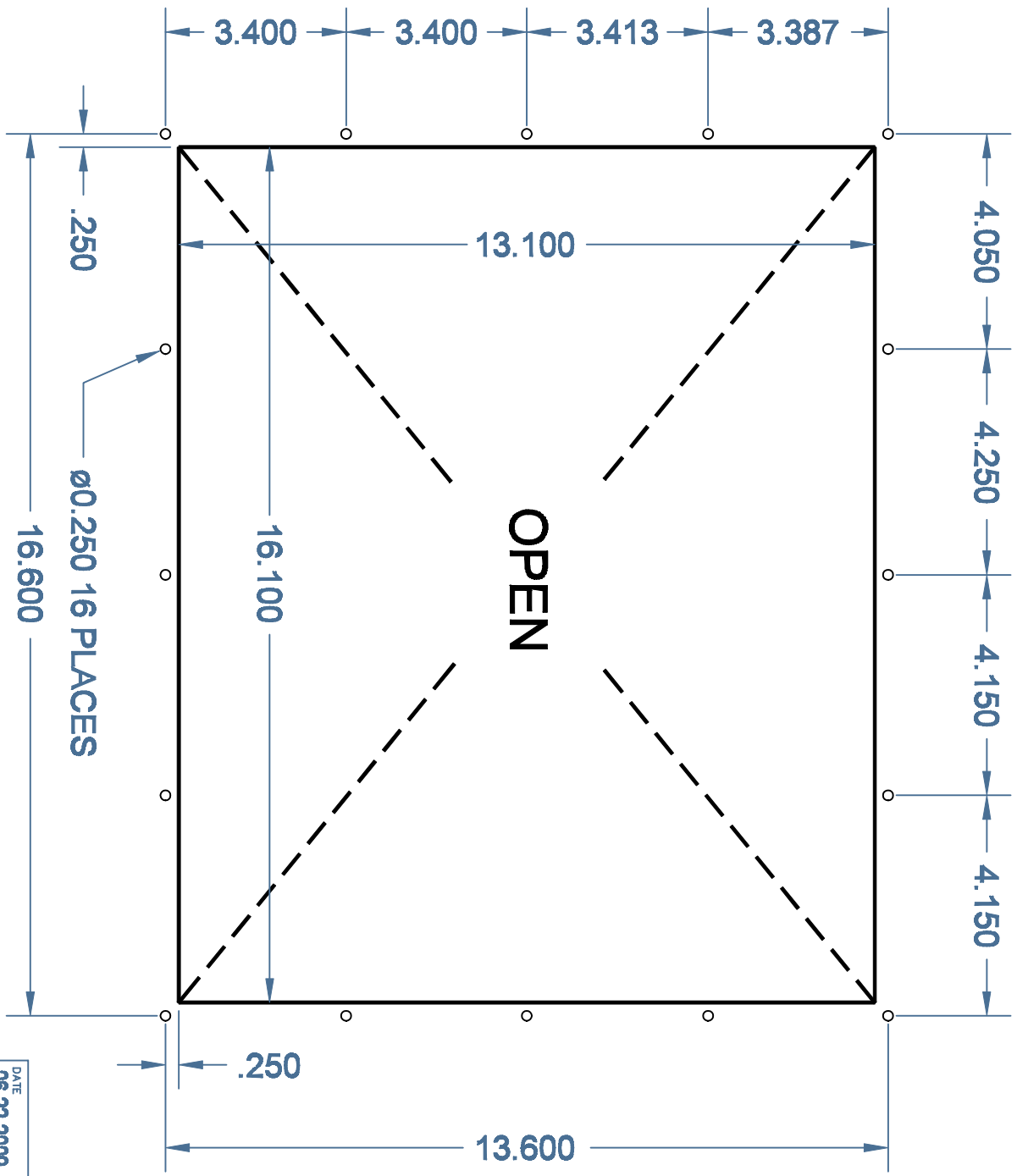

DATE	06-22-2009	DRAWN BY	B.G.	MODEL	TR-6001
PRODUCT	PANEL PC		REVISION		
FINISH	Transduction		CHECKED BY	NTS	
TITLE	CUTOUT			DRAWING No.	B-423
SCALE	NTS				

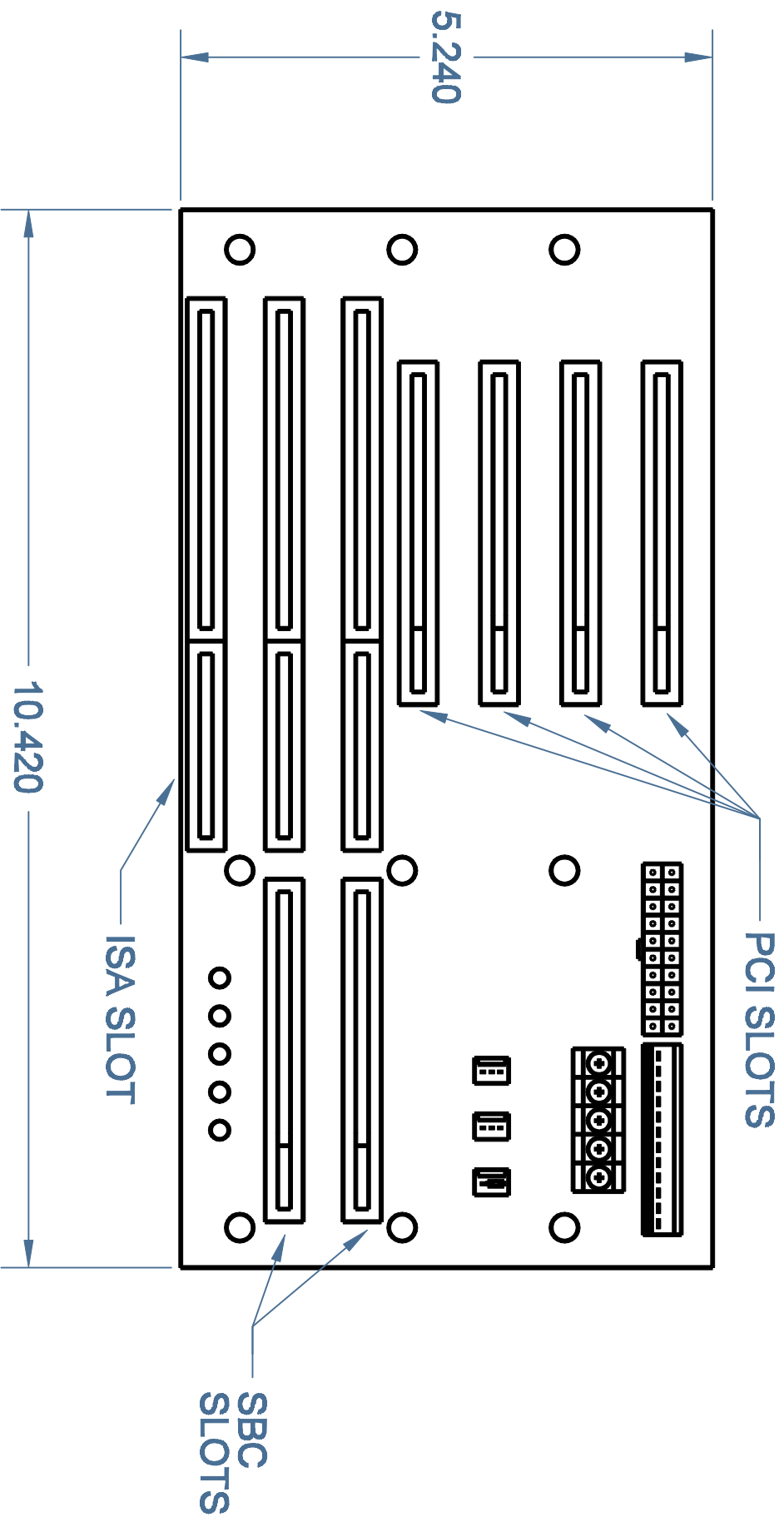

NOTE: ALL DIMENSIONS IN INCHES

DATE	06-22-2009	DRAWN BY	B.G.	MODEL	PCI-6S	
FINISH					REVISION	SCALE
TITLE	LAYOUT			DRAWING No	CHECKED BY	NTS
				B-435		

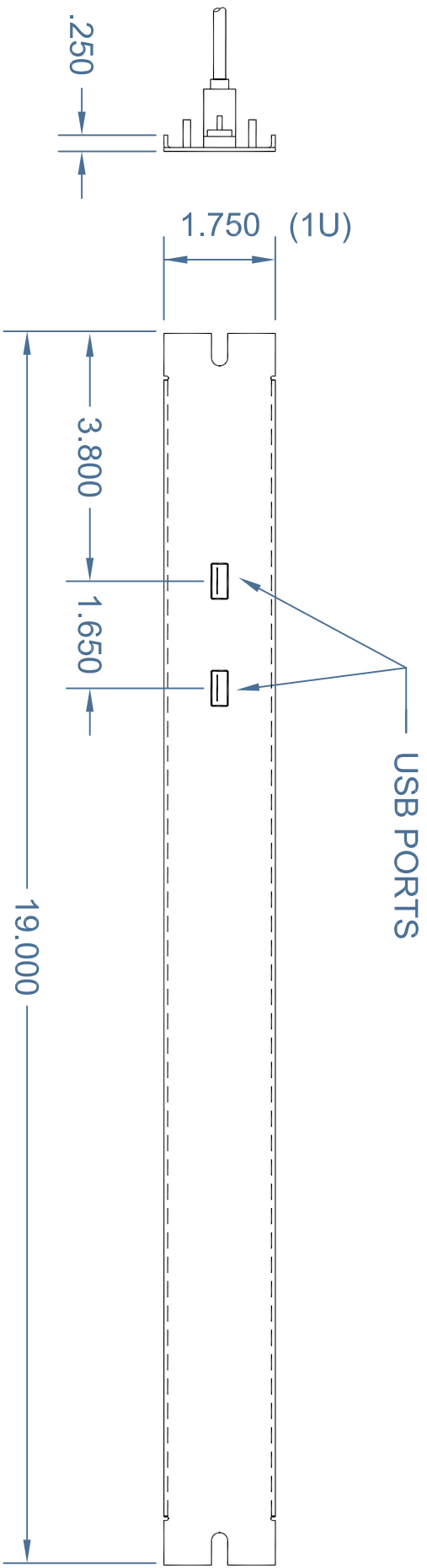

SIDE VIEW

FRONT VIEW

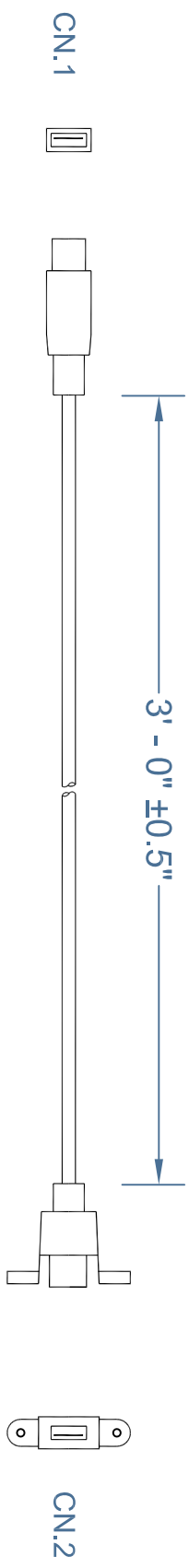

TWO USB CABLES  
MOUNTED ON THE PLATE

DATE	02-01-2010	DRAWN BY	B.G.	MODEL	1U USB FILLER
FINISH	SANDTEX BLACK PAINT	REVISION		CHECKED BY	NTS
TITLE	TR-RM-USB PLATE				SCALE
	LAYOUT		DRAWING NO		B-436A

STUD #6-32 x .500 4 PLACES FOR PANEL MOUNTING

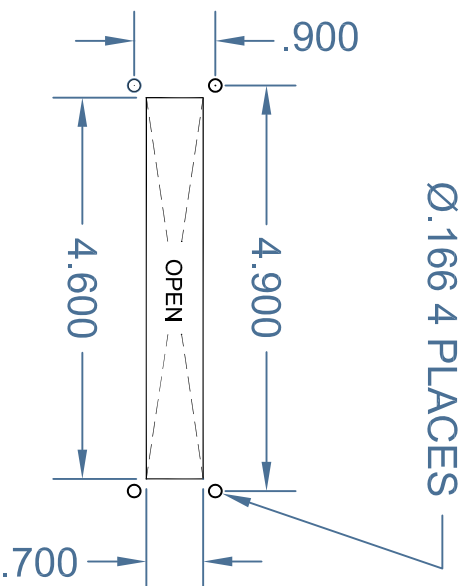
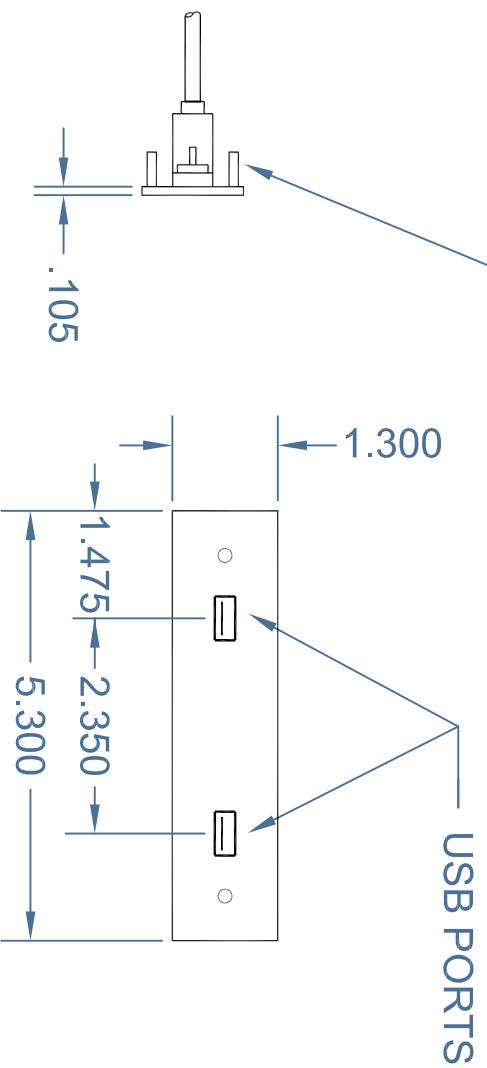

SIDE VIEW

FRONT VIEW

PANEL CUTOUT

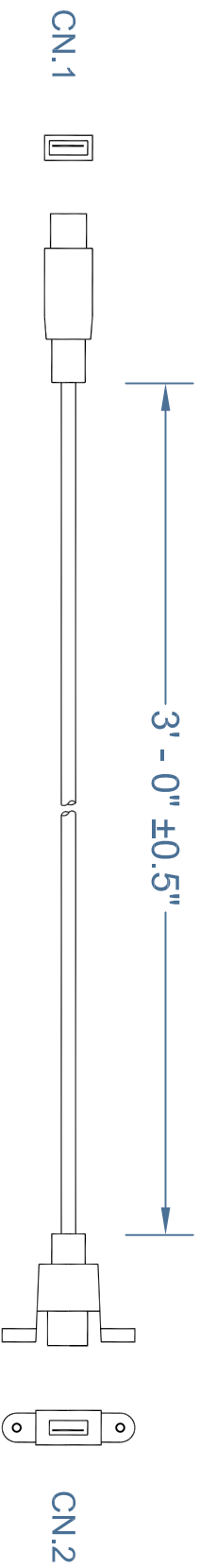

TWO USB CABLES  
MOUNTED ON THE PLATE

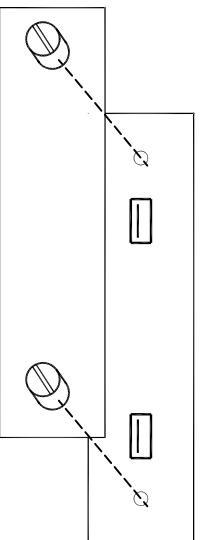

COVER PLATE

DATE	02-01-2010	DRAWN BY	B.G.	MODEL	FILLER PLATE	REVISION	SCALE
FINISH	SANDTEX BLACK PAINT				TR-PM-USB PLATE	CHECKED BY	NTS
TITLE	LAYOUT			DRAWING NO.	B-476A		
					Transduction		